

Use of Optocouplers in Battery Management Systems

Abstract

Optocouplers can present challenges when used in noisy environments. These devices are often used to provide an enable function in Battery Management Systems (BMS). This applications note discusses the issues that can occur in such systems when operating with high levels of system transients or Electromagnetic Interference (EMI), and provides simple solutions to the problems encountered.

Table of Contents

Introduction	2
Optocoupler Overview	3
Effects of System Transients	3
Effects of EMI	6
Conclusion	6

List of Figures

FIGURE 1. Battery Management System Diagram	2
FIGURE 2. Optocoupler Equivalent Circuit	3
FIGURE 3. Simplified Optocoupler Simulation Circuit	3
FIGURE 4. Input Waveform (V _x) used for Optocoupler Circuit Simulations	4
FIGURE 5. Enable Signal Waveforms Produced by Optocoupler Simulation	4
FIGURE 6. Detail of Enable Signal Waveforms	5
FIGURE 7. Recommended Optocoupler Circuit	5
FIGURE 8. Recommended Circuit of Figure 7 - Enable Signal Response to 3kV Common-Mode Transient	6

Introduction

The optocoupler's primary function is to transmit a signal across an isolation barrier. The isolation in the optocoupler is provided by a physical barrier between the input and output devices. Light generated by an integrated LED passes through this barrier and provides base current to the output bipolar transistor device. As with any isolation barrier there are parasitic "leakage" paths, which carry unwanted signals from input to output. The primary leakage elements in optocouplers are capacitive and provide a common-mode signal path between input and output, which responds to changes in the grounds associated with the input and output circuits.

Figure 1 shows a diagram of an automotive BMS. The system is split into two voltage domains: High Voltage (HV) and Low Voltage (LV). These domains are isolated from each other. The LV side is typically connected to system ground (chassis), while the HV side, which contains the batteries, is typically floating. Large transients can occur between the LV and HV grounds when the HV side is connected to another system, such as a battery charger, or when the battery charger changes current level abruptly. These transients, represented by voltage V_x in Figure 1, then appear directly across any optocoupler or other isolation devices used to carry signals between the LV and HV domains.

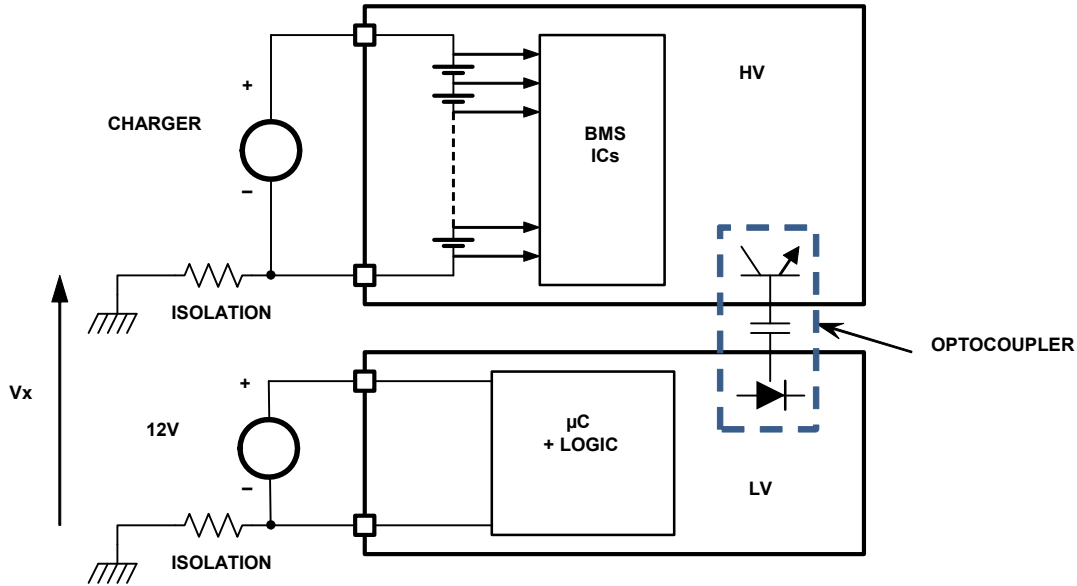

FIGURE 1. BATTERY MANAGEMENT SYSTEM DIAGRAM

Optocoupler Overview

A simplified equivalent circuit of an optocoupler is shown in [Figure 2](#).

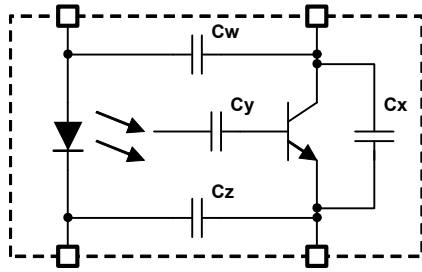

FIGURE 2. OPTOCOUPLER EQUIVALENT CIRCUIT

Referring to [Figure 2](#), capacitor C_x is dependent on the characteristics of the output transistor. Capacitors C_w , C_y and C_z are parasitic elements related to the process and layout of the optocoupler die. There are various techniques employed in the optocoupler design to minimize the effect of these parasitic elements, but the effects can never be completely eliminated. C_w and C_x are typically specified in optocoupler datasheets while C_y and C_z are not typically specified. Also note that C_w , C_y and C_z will have a strong voltage dependence so the effects seen in response to transients will vary with the voltage across the optocoupler.

Effects of System Transients

A simplified model of the optocoupler can be used to show the effect of the common-mode transients on the optocoupler output. [Figure 3](#) shows a circuit arranged to provide an enable function. The common-mode voltage between the LV and HV grounds is shown as V_x .

Note that the optocoupler output transistor is shown on the high-side of the enable output, with the load resistor (R_1) to ground. There are two reasons to choose this arrangement. The first is that the circuit draws no current when enable is low. The second concerns resistance to EMI. More on this later.

Simulations run with various values for external components R_1 , R_2 and C_1 show the effect of common-mode transients on the enable output signal. The waveform used for these simulations is shown in [Figure 4](#).

The enable signal response for various circuit arrangements is shown in [Figure 5](#), while [Figure 6](#) shows detail of the reset event signals. The enable input falling threshold (EN_{Vth}) is nominally $0.3 \times 3.3V$ or approximately $1V$ and is shown on [Figures 5](#) and [6](#) for reference.

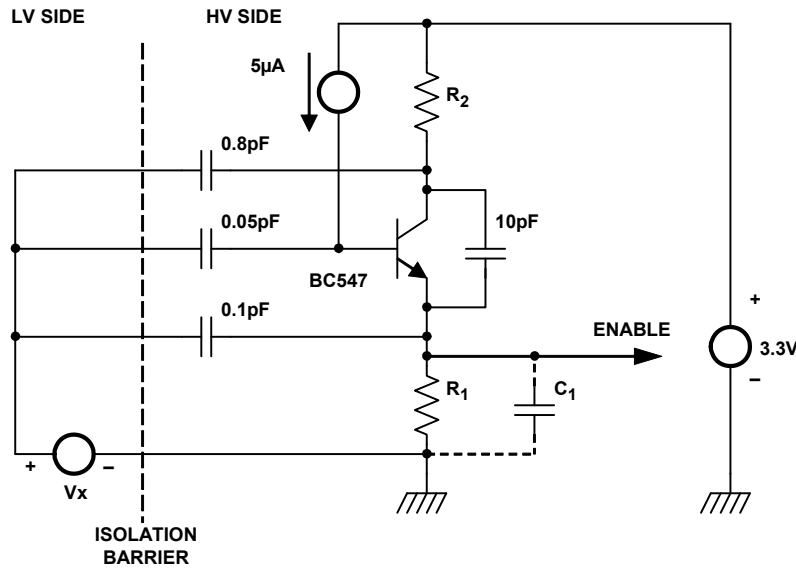

FIGURE 3. SIMPLIFIED OPTOCOUPLER SIMULATION CIRCUIT

Application Note 1975

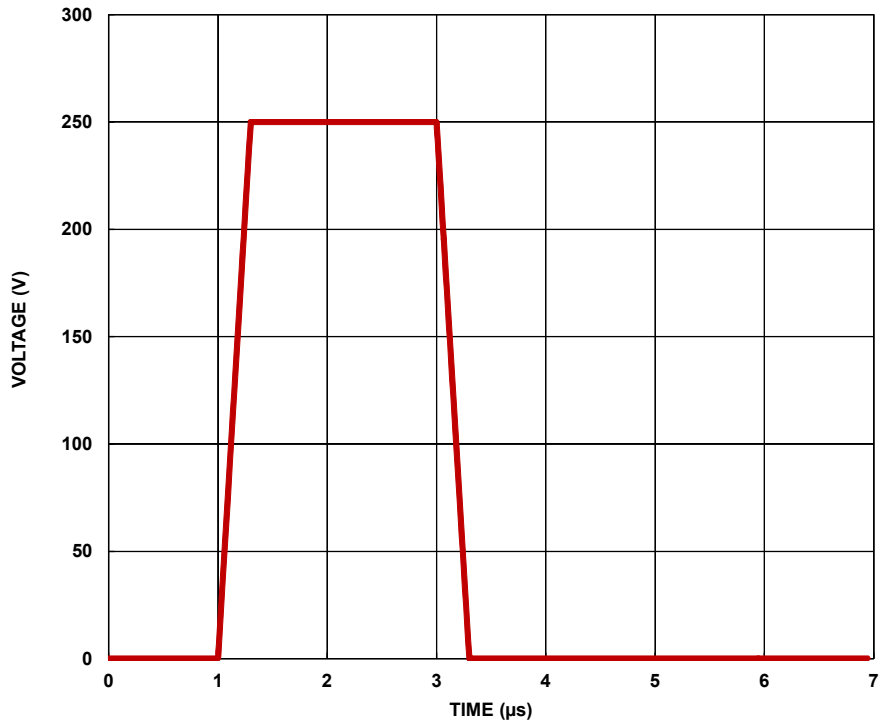

FIGURE 4. INPUT WAVEFORM (Vx) USED FOR OPTOCOUPLER CIRCUIT SIMULATIONS

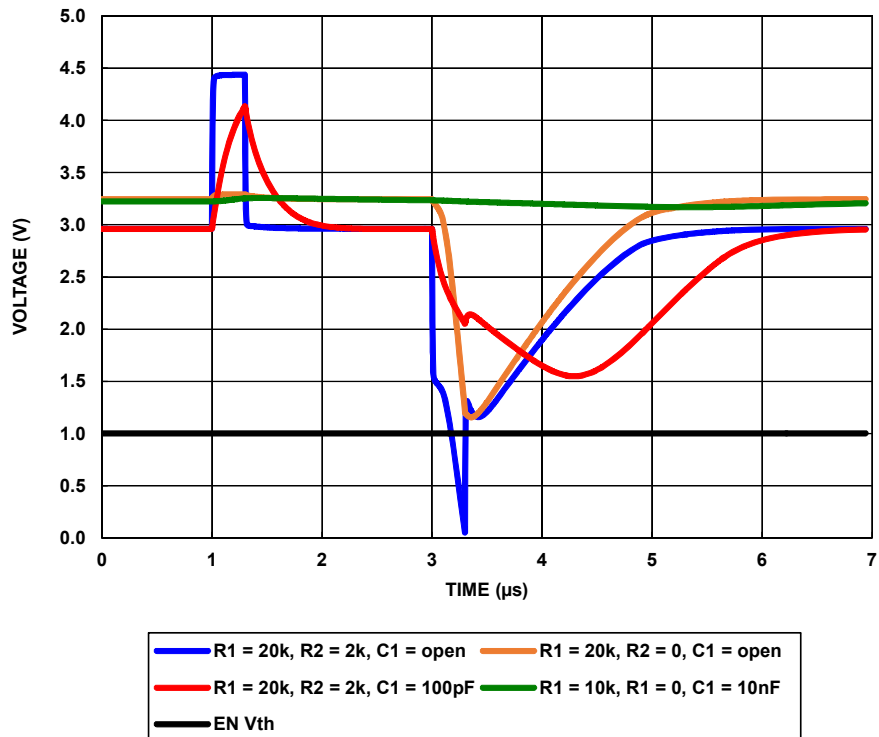

FIGURE 5. ENABLE SIGNAL WAVEFORMS PRODUCED BY OPTOCOUPLER SIMULATION

Application Note 1975

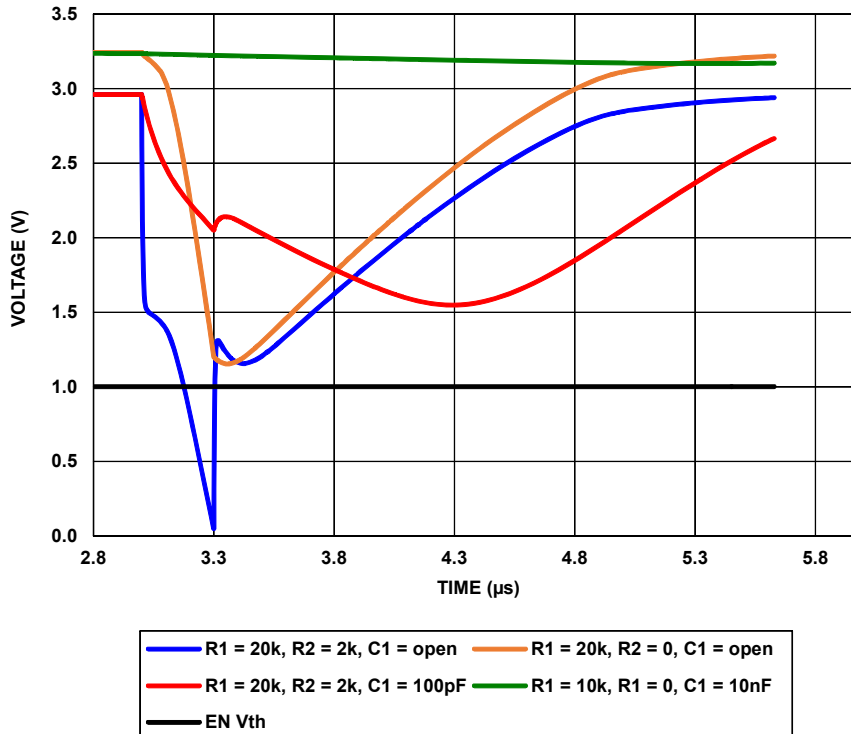

FIGURE 6. DETAIL OF ENABLE SIGNAL WAVEFORMS

Examination of [Figures 5](#) and [6](#) shows that, with an input transient of -250V, a reset event would occur with the case where $R_1 = 20k$ and $R_2 = 2k$. Other simulations show progressive improvement as R_2 is reduced in value or if C_1 is increased in value. The result when $R_1 = 10k$ and $C_1 = 10nF$, with R_2 is shorted, is seen in the green trace on [Figures 5](#) and [6](#). This leads to the recommended circuit arrangement shown in [Figure 7](#), which has only two components (R_1 and C_1). R_2 is not used.

An additional simulation shows the effect of a 3kV common-mode transient on the enable output of [Figure 7](#). The input (V_x) signal used for this simulation has the same form as that shown in [Figure 4](#), except that the peak value in this case is 3kV. The result can be seen in [Figure 8](#), which shows no reset event in response to a 3kV transient.

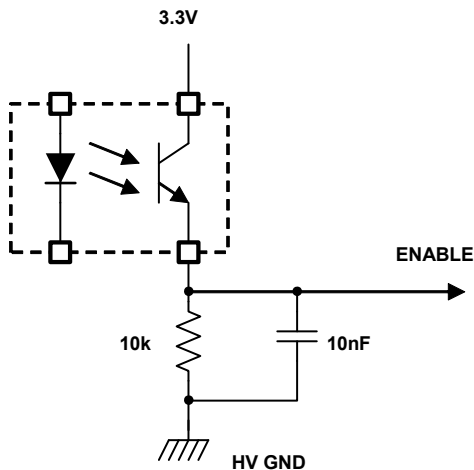

FIGURE 7. RECOMMENDED OPTOCOUPLER CIRCUIT

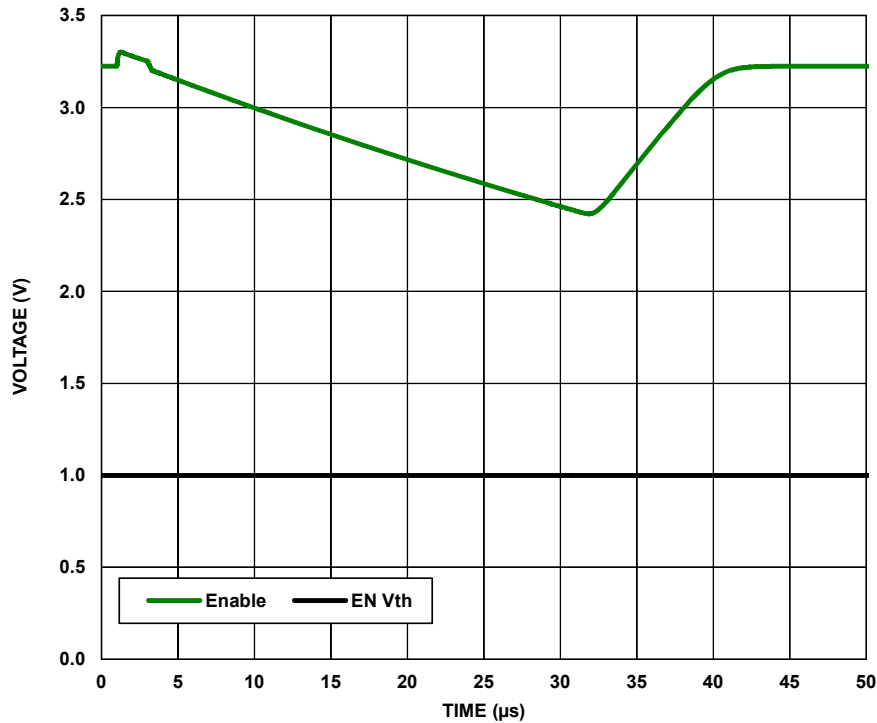

FIGURE 8. RECOMMENDED CIRCUIT OF [FIGURE 7](#) - ENABLE SIGNAL RESPONSE TO 3kV COMMON-MODE TRANSIENT

Effects of EMI

High frequency modulation of the isolation voltage V_x couples to the optocoupler output transistor base through capacitor C_y (see [Figure 2](#)). This results in an average DC current flowing from the emitter of the output transistor through the load resistor R_1 (see [Figure 3](#)). This effect of this is often seen as a delay in the time required to turn off the Enable signal in cases where the system is subject to high levels of EMI and value of R_1 is too large, and can be reduced or eliminated simply by reducing the value of R_1 . For example, reducing the value of R_1 from 10k to 1k will improve EMI immunity by a factor of 10. The only penalty of this change is an increase in the current drawn by the Enable circuit, when the enable signal is high, from 330µA (10k) to 3.3mA (1k).

Conclusion

Optocoupler circuits need careful design to eliminate effects due to system transients and EMI. The simple addition of a filter capacitor can provide immunity to transient voltages in excess of 3kV. EMI effects are addressed by appropriate selection of the optocoupler load resistor.

Intersil Corporation reserves the right to make changes in circuit design, software and/or specifications at any time without notice. Accordingly, the reader is cautioned to verify that the document is current before proceeding.

For information regarding Intersil Corporation and its products, see www.intersil.com