

Application Note AN140101

Use of ISP130301 Development Kit

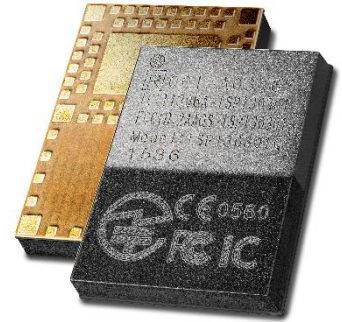

Introduction

Scope

This document gives details on hardware and software for using and testing Insight SiP Bluetooth Low Energy module ISP130301-xx (models ISP130301-BM, ISP130301-BL, ISP130301-AM).

Contents

1.	Recommended Documentation	2
2.	ISP130301 Dev Kit Hardware Content.....	3
3.	Software Installation.....	4
4.	Hardware Description	6
4.1.	ISP130301-xx Module	6
4.2.	ISP130301-xx-TB Test Board	6
4.3.	ISP131001 Sensors Board	7
4.4.	ISP130603 Interface Board	8
4.5.	nRF51822 Development Dongle	8
5.	Basic Application using ISP130301-xx-TB Test Board.....	9
5.1.	Basic BLE Proximity Application	9
5.2.	Direct Test Mode (UART).....	17
5.3.	UART Mode Example.....	22
5.4.	BLE UART Mode Example.....	25
6.	Basic Sensor Application with ISP131001	29
6.1.	On Master Control Panel	29
6.2.	On iPhone or iPad Device	31
6.3.	On Android Device	33

1. Recommended Documentation

The following Nordic Semiconductor documents and Dev Kits (software portion) are required to understand the complete setup and programming methods:

Documents:

- + nRF51822 Development kit User Guide (hardware section should be partially ignored – ISP development kit hardware replaces Nordic Semiconductor hardware).
- + nRF51 Series Reference Manual.
- + nRF51822 PS (data sheet).
- + S110 nRF51822 SoftDevice Specification.
- + nRF5 SDK (for software development on the nRF51 and nRF52 Series).

To access documentation, information, go to:

- + <http://www.nordicsemi.com> (Official Nordic Semi website)
- + <http://infocenter.nordicsemi.com/index.jsp> (The Nordic Semiconductor Infocenter is a “comprehensive library” containing technical documentation for current and legacy solutions and technologies)
- + <https://devzone.nordicsemi.com/questions> (Ask any Nordic related question and get help)
- + For any question, you can also open a case on the <http://www.nordicsemi.com>

Dev kits (software portion):

- + nRFgo Studio.
- + nRF5 Software Development Kit (SDK):
 - Precompiled HEX files.
 - Source code.
 - Keil ARM project files.
- + S110 nRF51822 SoftDevice.
- + Master Control Panel.

To access these files, go to www.nordicsemi.com and download the files. Instructions can be found in Chapter 3.

Other ISP documents that complete the above:

- + AN140101 App Note – this document.
- + DS130301 module data sheet.
- + ISP130301-xx-TB Test Board schematic SC130602.
- + ISP130603 Interface Board schematic SC130604.
- + ISP131001 Sensors Board schematic SC131002.

2. ISP130301 Dev Kit Hardware Content

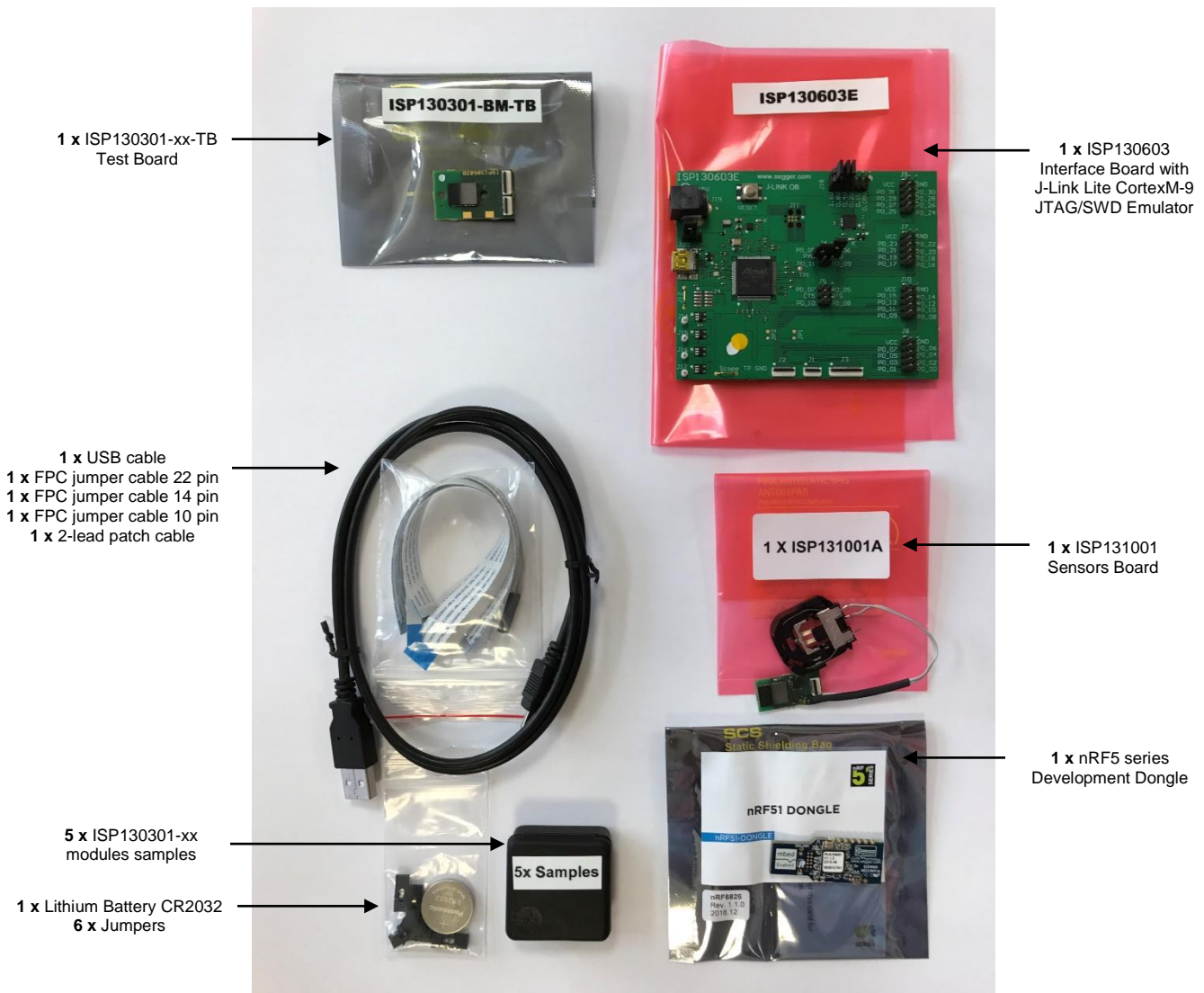

3. Software Installation

This paragraph describes the steps to follow for software installation.

1. Download and install Keil MDK-ARM from <https://www.keil.com/demo/eval/arm.htm> to your hard drive. After installation, a Pack Installer window appears. Click on the “Packs” section and “Check for updates”. After you can show in the Device section “Nordic Semiconductor” on the left side of the screen and different Packs available on the right side of the screen.

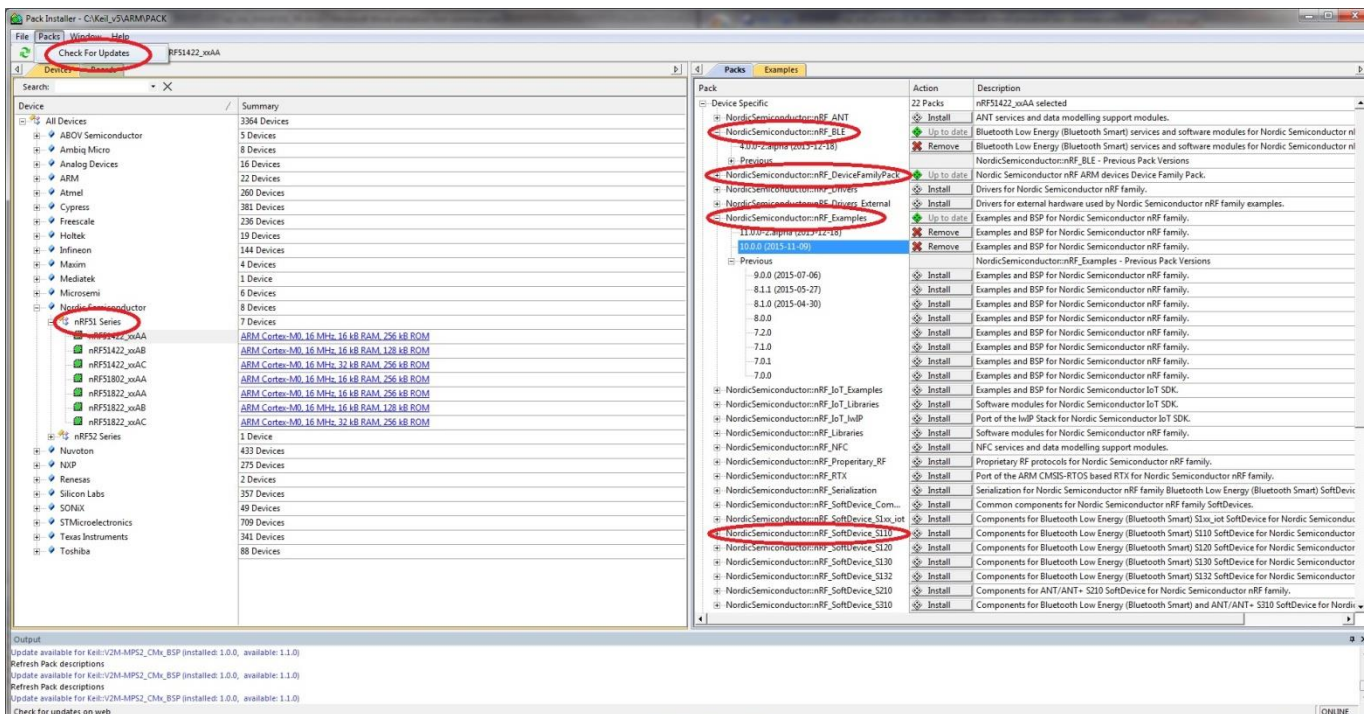

On the “Packs” section, you can download and update Nordic example, nRF SoftDevice, nRF DeviceFamilyPack, nRF examples..., etc ...

All the Packs are installed on the following directory: C:\Keil_v5\ARM\Pack\NordicSemiconductor.

2. Download and run the J-Link Software and documentation pack for Windows from <http://www.segger.com/jlink-software.html>. The serial number from your SEGGER J-Link hardware is needed to identify your device and can be found printed on the chip on the J-Link Lite emulator board.
3. Go to www.nordicsemi.com and log in to your Nordic My Page account.

4. Go to Products and click on Bluetooth Smart/Bluetooth Energy. You will have access to the different product :
 - a. nRF51 Series : Click on nRF51822 and on the download section you have access to the documentation, SoftDevice, Master control panel, nRFgo studio, SDK ... etc ...
 - b. nRF5X Development Tools: You can download the last nRF5 SDK.
5. You can also download the SDK in the following link: <https://developer.nordicsemi.com/>.
6. Download, install nRFgo Studio (Make sure to download the last version updated).
7. Download, install Master Control Panel (*x86 is for 32 bits windows and x64 is for 64 bits windows*).

4. Hardware Description

4.1. ISP130301-xx Module

ISP130301-xx is a Bluetooth Low Energy module with integrated antenna of the selected version

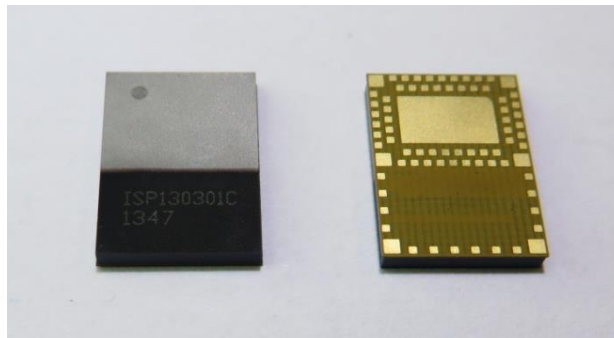

This module is based on Nordic Semiconductor nRF51822 2.4 GHz wireless SoC. nRF51822 integrates nRF51 series 2.4 GHz transceiver, a 32 bit ARM Cortex™-M0 CPU, flash memory, and analogue and digital peripherals. nRF51822 can support Bluetooth low energy and a range of proprietary 2.4 GHz protocols. The ISP130301 module measures 8 x 11 x 1.2 mm³. The module integrates all the decoupling capacitors, the 16 MHz and 32 kHz crystals, their load capacitors, the DC-DC converter component, the RF matching circuit and the antenna in addition to the wireless SoC. For more details, see Insight SiP module data sheet (document DS130301).

4.2. ISP130301-xx-TB Test Board

ISP130301-xx-TB is the basic application test board that has dimensions of 18 x 30 mm².



It encloses:

- + ISP130301 BLE module
- + 3 x FPC connectors in order to access the nRF51822 GPIOs:
 - 1 x 10 pin FPC connector on top side of the board.
 - 1 x 14 pin FPC connector on top side of the board.
 - 1 x 22 pin FPC connector on bottom side of the board.

The ISP130301-xx-TB electrical schematic is presented in document SC130602.

4.3. ISP131001 Sensors Board

ISP131001 is the sensor application board that has dimensions of 12.5 x 25 mm².

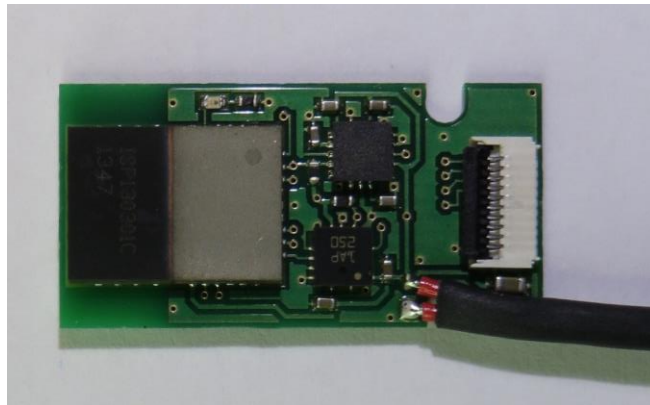

It encloses:

- + ISP130301-BM BLE module.
- + ST Micro LPS331AP temperature and barometer sensor.
- + Freescale FXOS8700CQ 6-axis linear accelerometer and magnetometer sensor.
- + Rohm SML-P11MTT86 mini-LED.
- + Software to read/drive the sensors.
- + Removable 10 pin FPC connector for software loading.

The ISP131001 electrical schematic is presented in document SC131002.

4.4. ISP130603 Interface Board

ISP130603 is the application type interface board that has dimensions of 100 x 80 mm². The ISP130603 electrical schematic is presented in document SC130604.

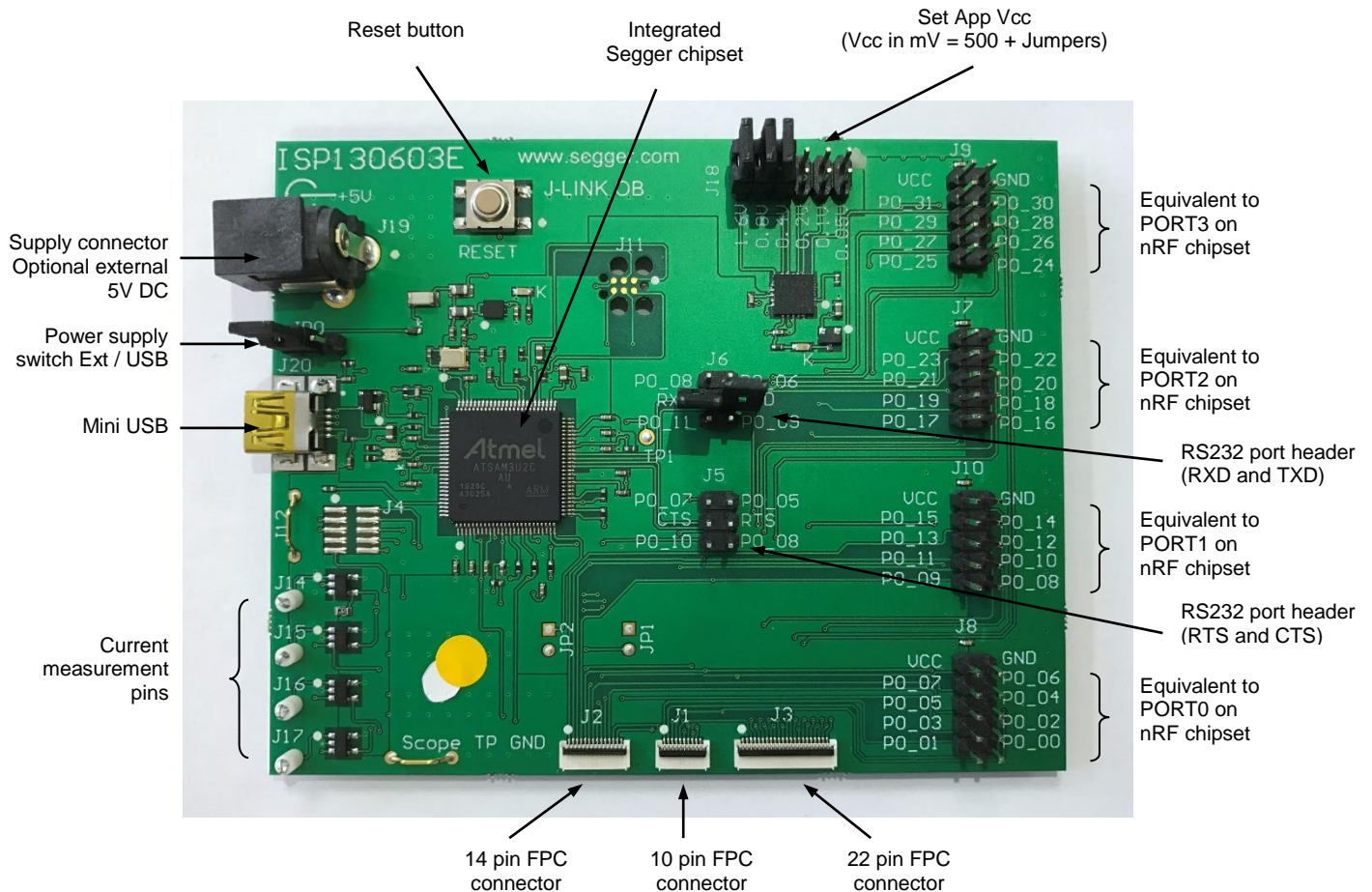

4.5. nRF51822 Development Dongle

The reader should refer to the corresponding paragraph in nRF51822 Development Kit User Guide document.

5. Basic Application using ISP130301-xx-TB Test Board

5.1. Basic BLE Proximity Application

This paragraph shows you how to set up and program a BLE proximity application on top of a SoftDevice that will send data on a Bluetooth link from the ISP130301-xx-TB Test Board to the Master Emulator. In order to use Bluetooth Low Energy radio, the software is loaded in 2 parts:

- ✚ S110 SoftDevice using nRFgo Studio (hex file, no source).
- ✚ Proximity Application using Keil uVision.

Then Master Emulator is connected and Proximity Application is launched.

S110 SoftDevice loading

1. Connect the provided USB cable from the Interface Board ISP130603 to your computer.
2. Connect the ISP130301-xx-TB Test Board to the ISP130603 Interface Board with the 10 pin, 14 pin and 22 pin FPC jumper cables (0.5 mm pitch, provided in the Development Kit)

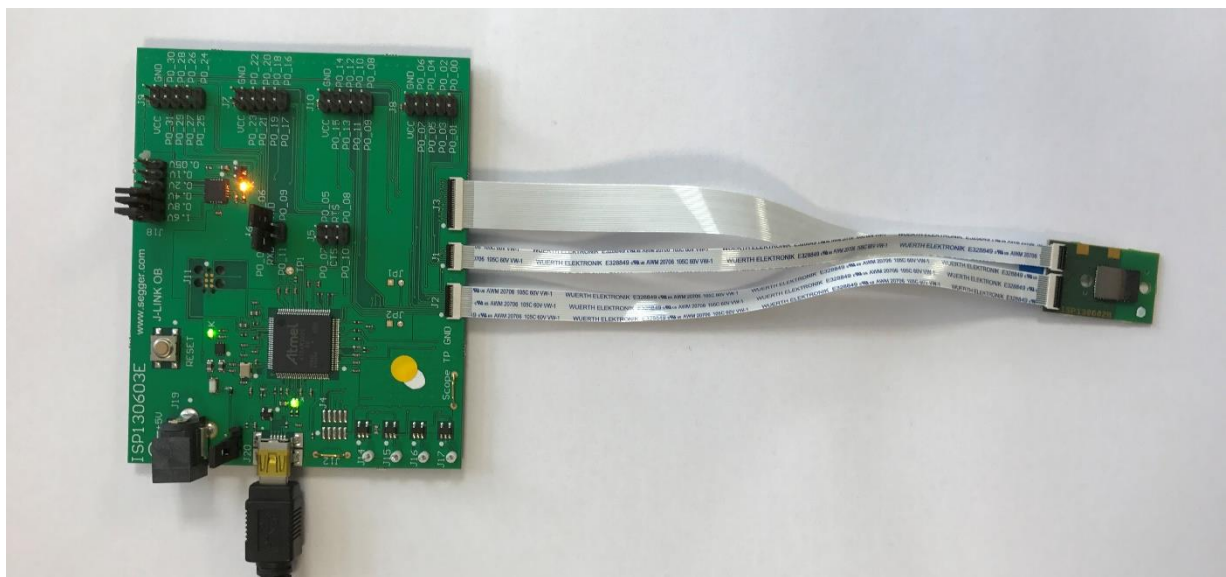

3. Start nRFgo Studio.
4. Select nRF5x Programming.
5. Click Erase all.

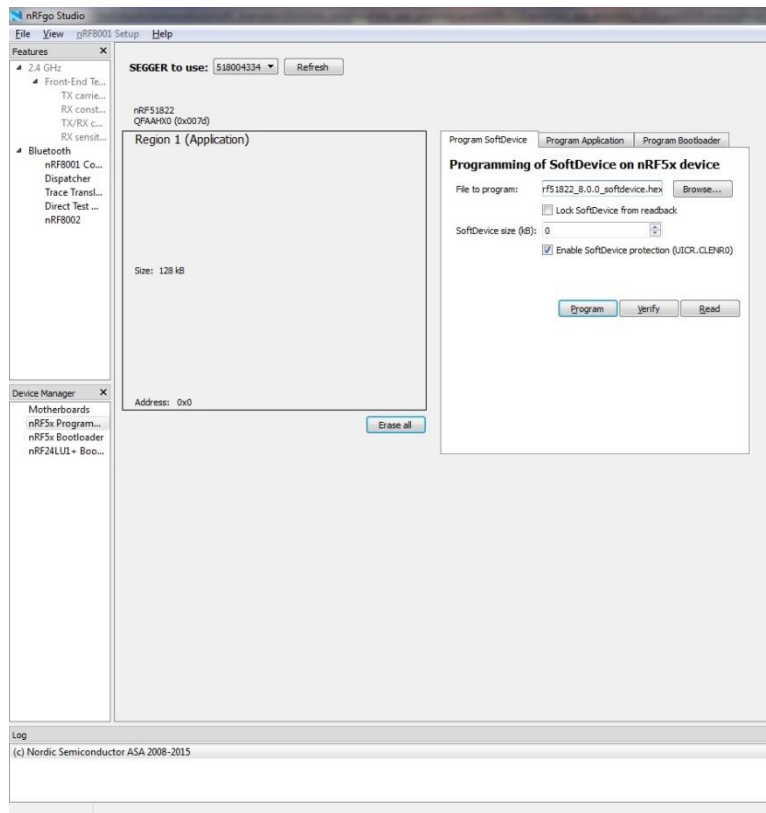

6. Browse to SoftDevice hex file and click Program. The SoftDevice is available on the Nordic Website or by installing the SoftDevice S110 with the Pack Installer, for example :
C:\Keil_v5\ARM\Pack\NordicSemiconductor\nRF_SoftDevice_S110\8.0.3\hex

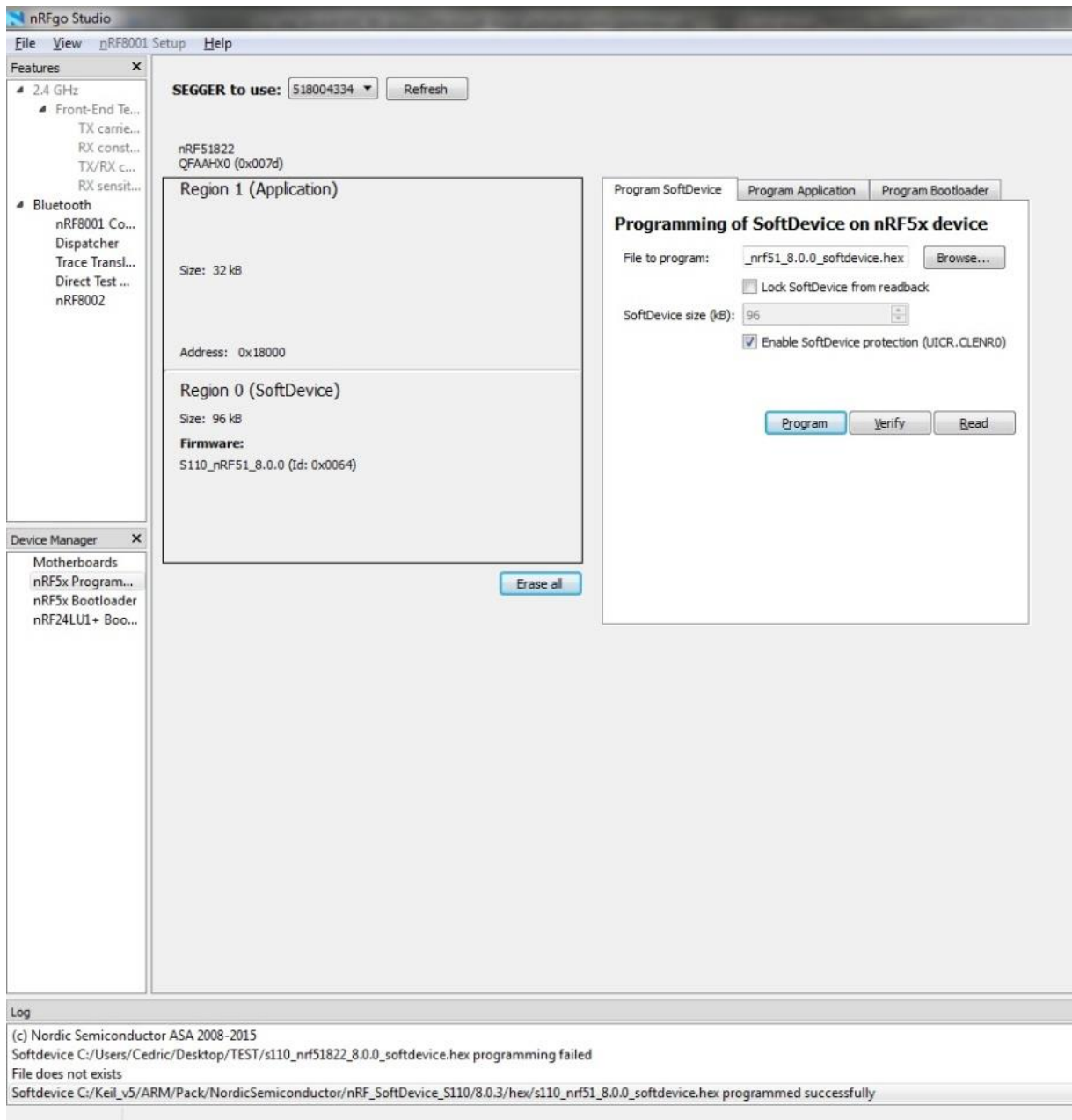

The screenshot shows the nRFGo Studio interface. On the left, the 'Features' tree is expanded to 'Bluetooth' > 'nRF8001 Co...'. The 'Device Manager' shows 'Motherboards' > 'nRF5x Program...'. The main area displays memory regions for an nRF51822 device (QFAAHX0, 0x007d):

- Region 1 (Application)**: Size: 32 kB, Address: 0x18000
- Region 0 (SoftDevice)**: Size: 96 kB, Firmware: S110_nRF51_8.0.0 (Id: 0x0064)

The 'SEGGER to use' dropdown is set to '518004334'. The 'Programming of SoftDevice on nRF5x device' panel shows:

- File to program: `_nrf51_8.0.0_softdevice.hex`
- SoftDevice size (kB): 96
- Options: Lock SoftDevice from readback, Enable SoftDevice protection (UIICR.CLENR0)
- Buttons: Program, Verify, Read

The Log window at the bottom shows:

```
(c) Nordic Semiconductor ASA 2008-2015
Softdevice C:/Users/Cedric/Desktop/TEST/s110_nrf51822_8.0.0_softdevice.hex programming failed
File does not exists
Softdevice C:/Keil_v5/ARM/Pack/NordicSemiconductor/nRF_SoftDevice_S110/8.0.3/hex/s110_nrf51_8.0.0_softdevice.hex programmed successfully
```

Proximity Application loading

1. Start Keil uVision.
2. Select Project then Open Project in order to open Proximity app. Make sure it is the right file project. The project is locked, it is read only, if you want to modify it, you have to change the right in the file App directory properties.

(Ex: C:\Keil_v5\ARM\Pack\NordicSemiconductor\NRF_Examples\10.0.0\ble_peripheral\ble_app_proximity\pca10028\s110\arm5\ble_app_proximity_s110_pca10028.uvprojx).

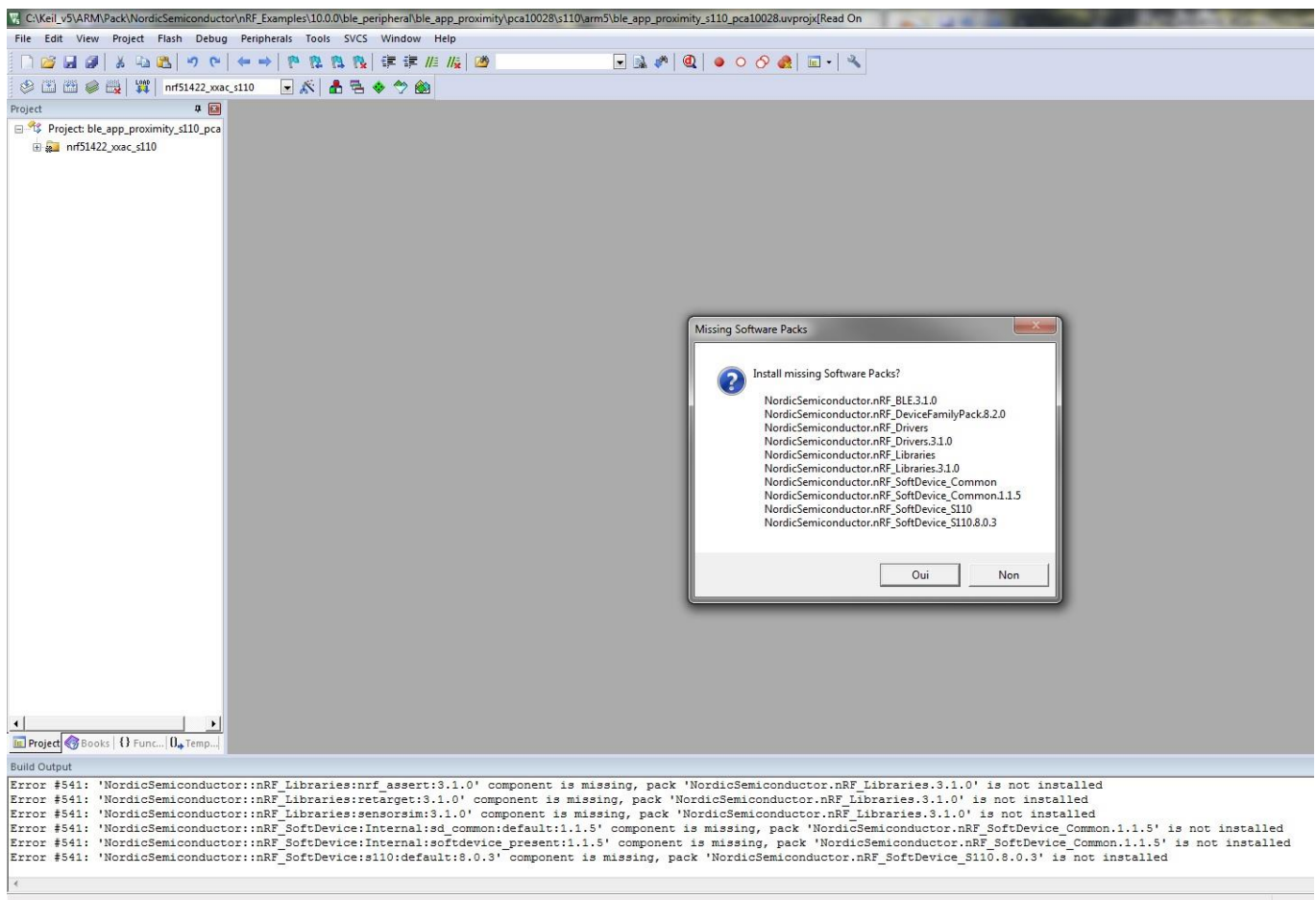

If some Install Softwares Packs is missing, a window appears, and you can install it.

3. Click Build Target and Load. If you have this message after click Load, it means that the power is not enough and you have to increase the voltage by adding jumpers on the interface board.



You can also load the hex file (generated after building target with keil uVision) by nRFgo studio in the program application.

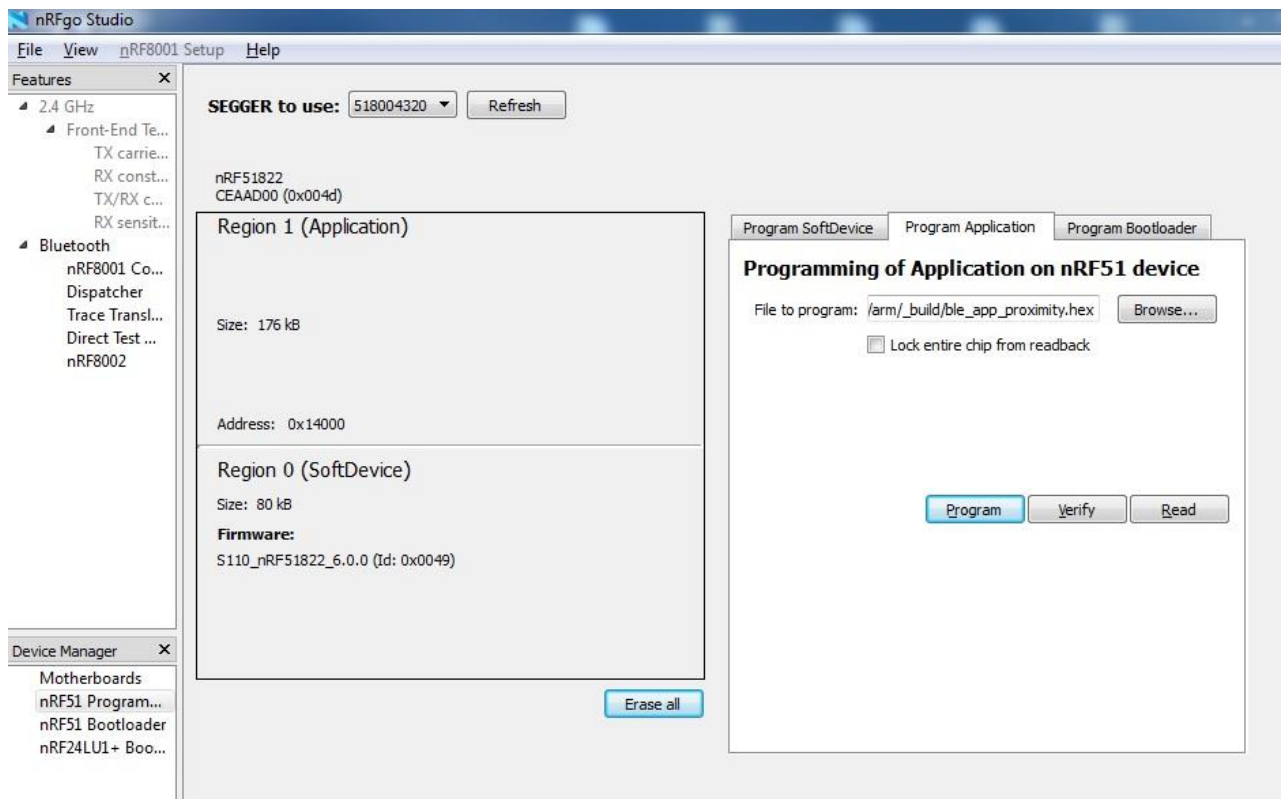

The file project is located for example:

C:\Keil_v5\ARM\Pack\NordicSemiconductor\NRF_Examples\10.0.0\ble_peripheral\ble_app_proximity\pc a10028\s110\arm5_build\nrf51422_xxac_s110.hex).

Master Emulator and Proximity Application

1. Connect nRF51 Dongle (Master Emulator) into a USB port on your computer.
2. Start Master Control Panel. If you have no master emulator found, you have to flash the dongle in Flash programming section.

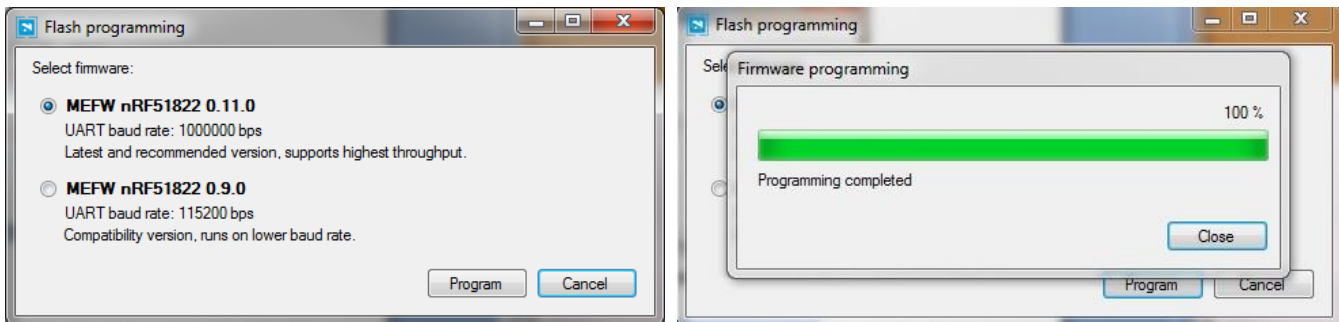

3. Click Start Discovery.

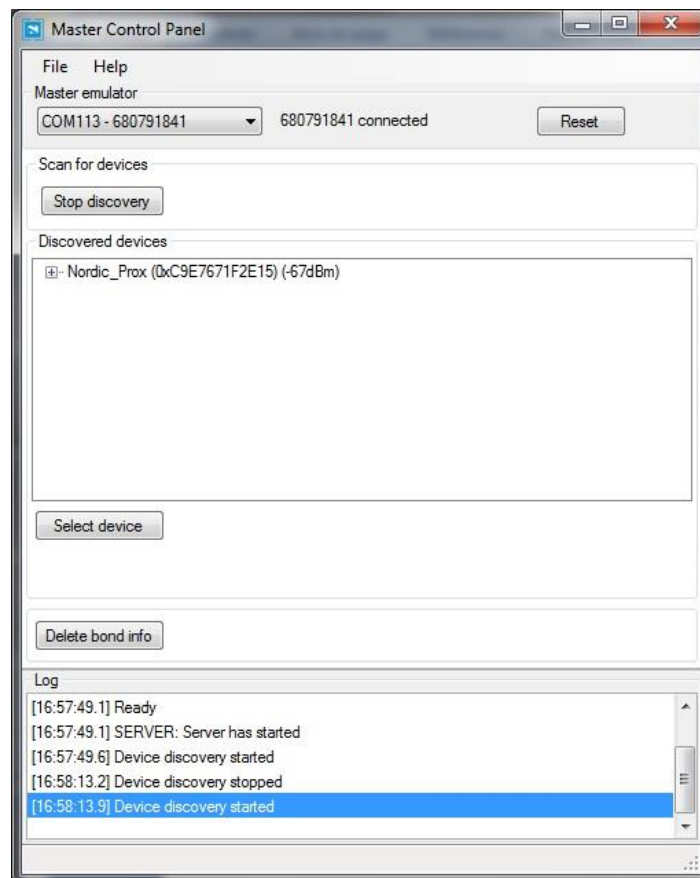

4. After starting discovery, if no device appearing, disconnect and connect again the interface board power supply.
5. If you have an error message as indicated in the photo :

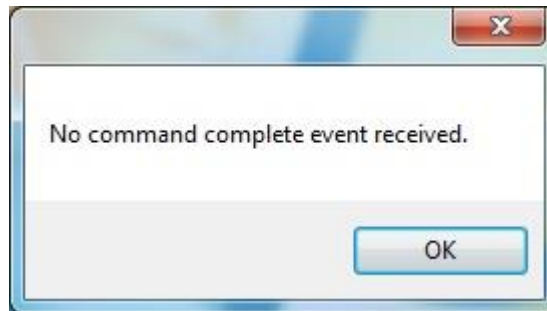

It means that the nRF51 Dongle is not programmed. For your information, please refer to the nRF51822 Development Kit User Guide document as indicated in our application note ISP130301-DK1 part 4.5 on page 14-7. You can find this user guide on the Nordicsemi website. The procedure to program the nRF51 Dongle is described on page 13. I enclose a copy of the user guide for your convenience.

- 1) *Open the Master Control Panel from the Start menu (Start > All Programs > Nordic Semiconductor > Master Control Panel).*
 - 2) *Make sure the Development Dongle is detected. The Master Emulator item list should show COMnn-xxxxxxx (nn gives the COM port number; xxxxxxxx is the SEGGER serial number printed on the dongle). Restart the application if it doesn't appear in the item list. Before continuing, make sure you have selected the correct device by verifying the serial number in the item list with the serial number printed on the Development Dongle.*
 - 3) *When you use the Development Dongle for the first time, you must first program it with the Master Emulator Firmware.*
 - a. *In the Master Control Panel menu click File and select Flash Programming.*
 - b. *Click Browse. This opens a browser that automatically points to the location of the*
 - c. *mefw_nrf51822_<version>_firmware.hex (<version> will be replaced by a number*
 - d. *giving the version of the actual firmware).*
 - e. *The Master Control Panel Firmware file is located in:*
 - f. *C:\Program Files (x86) \ Nordic Semiconductor \ Master Control Panel \<version>\firmware*
 - g. *pca10000\MEFW_nRF51822_<version>_firmware.hex.*
 - h. *Select the Master Emulator Firmware file and click Open.*
 - i. *Click Program to start programming the selected device.*
 - j. *When the programming is finished click Exit to go back to the main window.*
6. Click Select Device.
 7. On the following display, click successively on Bond, Discover Services and Enable Services.

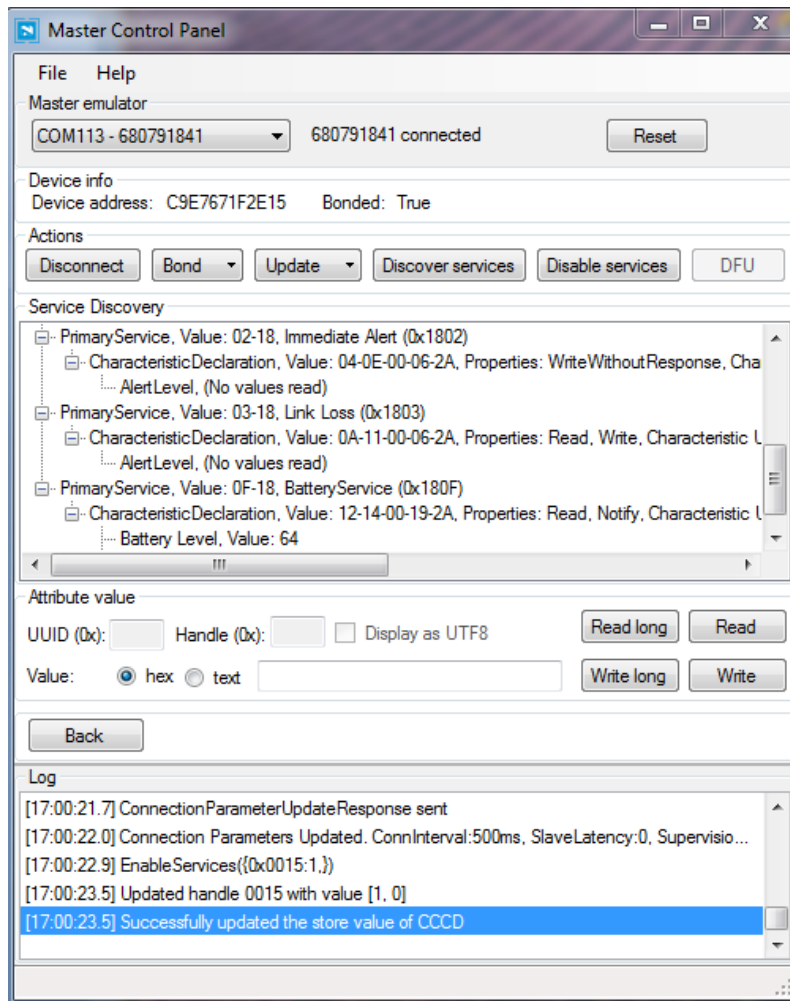

8. You can note Battery voltage is sent by the ISP130301-xx-TB Test Board to the Master Emulator via the Bluetooth link. The application is written to send a value that changes cyclically.

Important notification: Pay attention to the compatibility between the IC revision, the SoftDevice, the nRF51 SDK, etc, ... Please read the [nRF51 Series Compatibility Matrix vX.X.pdf](#) available on the Nordic website.

For example, if you use the SoftDevice 8.0.0, you cannot use the nRF51 SDK 7 or 6 due to some API changes in the release.

5.2. Direct Test Mode (UART)

This paragraph shows you how to set up and program the Direct Test Mode through the UART on ISP130301-xx-TB Test Board.

Direct Test Mode Set-up

1. Connect the USB cable from the Interface Board ISP130603 to your computer.
2. Connect the ISP130301-xx-TB Test Board to the ISP130603 Interface Board with the 10 pin, 14 pin and 22 pin FPC jumper cables (0.5 mm pitch, provided in the Development Kit)
3. On the ISP130603 Interface Board, connect the 2-lead patch cable in order to connect:
 - RXD to P0_11
 - TXD to P0_09

Make sure the RXD/TXD labels match for each wire. This matches the default setting if you are using the Nordic Board PCA10028 in the SDK project (be careful: depending on the Nordic Board version you are using, the ports used could be different, see next part: Direct Test Mode loading).

Direct Test Mode Loading

1. Start Keil uVision.
2. Select Project then Open Project in order to open Direct Test Mode application:
C:\Keil_v5\ARM\Pack\NordicSemiconductor\RF_Examples\10.0.0\dtm\direct_test_mode\pca10028\blank\arm5\ direct_test_mode_blank_pca10028.uvprojx.

Warning: Regarding the Nordic Board you are using, the RX and TX pin number could be different. In the following pictures, the Nordic board PCA10028 is used (you can modify the Nordic Board model in : Flash → Configure Flash Tools → C/C++, by writing the correct Board name in the “Define” area with the name indicated in the boards.h).

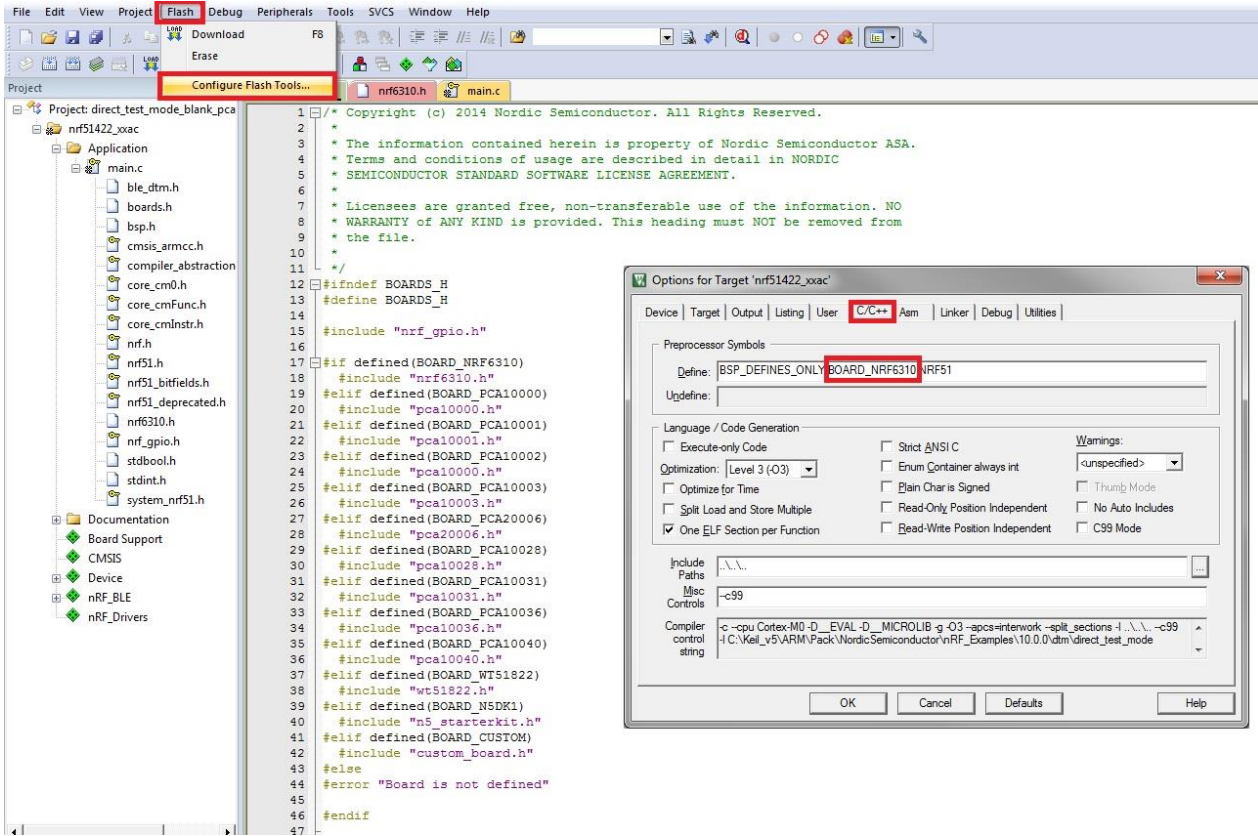

In the following picture, the Nordic board PCA10028 is used by default and the RX and TX pin number are 11 and 09.

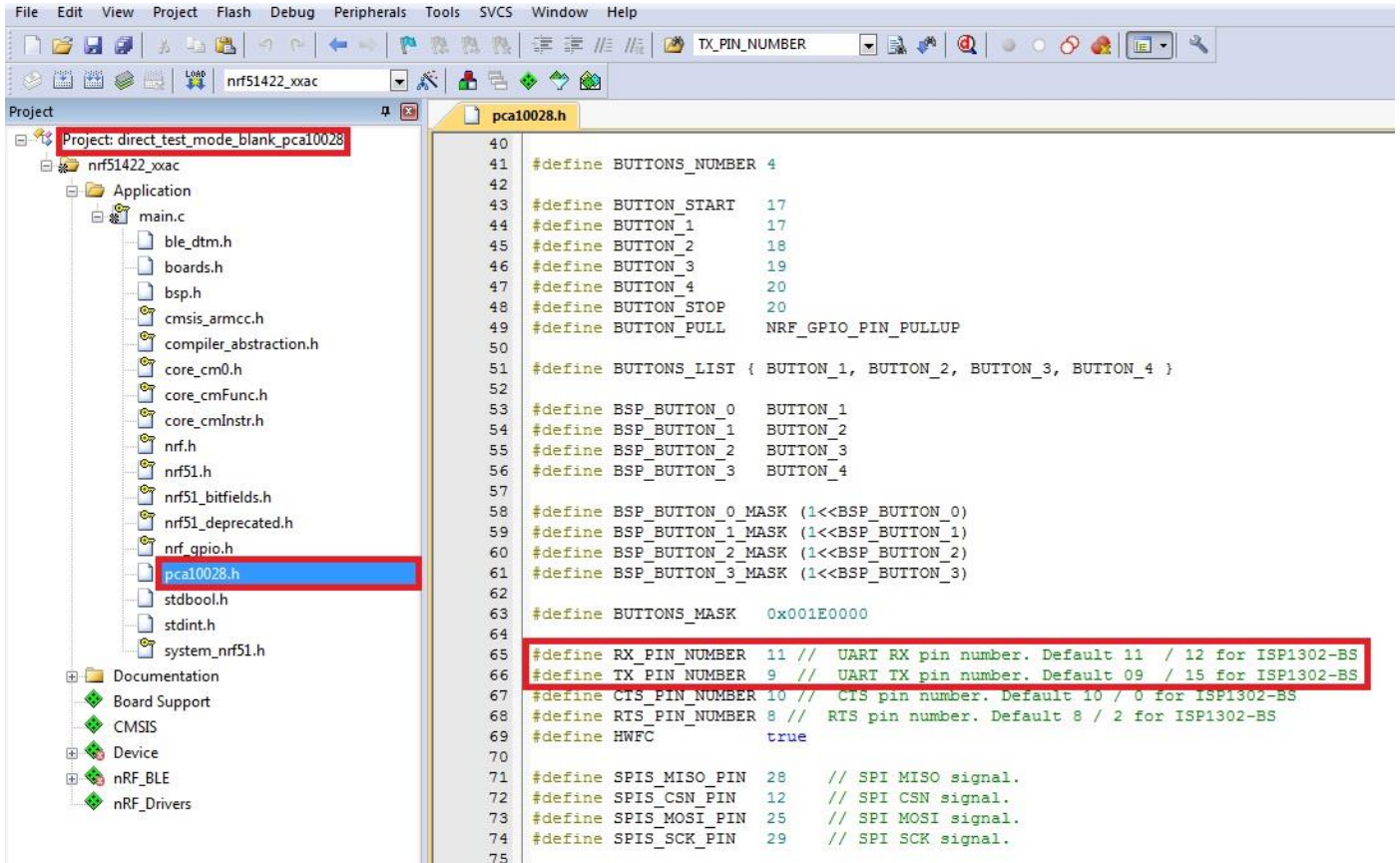

```

40
41 #define BUTTONS_NUMBER 4
42
43 #define BUTTON_START 17
44 #define BUTTON_1 17
45 #define BUTTON_2 18
46 #define BUTTON_3 19
47 #define BUTTON_4 20
48 #define BUTTON_STOP 20
49 #define BUTTON_PULL NRF_GPIO_PIN_PULLUP
50
51 #define BUTTONS_LIST { BUTTON_1, BUTTON_2, BUTTON_3, BUTTON_4 }
52
53 #define BSP_BUTTON_0 BUTTON_1
54 #define BSP_BUTTON_1 BUTTON_2
55 #define BSP_BUTTON_2 BUTTON_3
56 #define BSP_BUTTON_3 BUTTON_4
57
58 #define BSP_BUTTON_0_MASK (1<<BSP_BUTTON_0)
59 #define BSP_BUTTON_1_MASK (1<<BSP_BUTTON_1)
60 #define BSP_BUTTON_2_MASK (1<<BSP_BUTTON_2)
61 #define BSP_BUTTON_3_MASK (1<<BSP_BUTTON_3)
62
63 #define BUTTONS_MASK 0x001E0000
64
65 #define RX_PIN_NUMBER 11 // UART RX pin number. Default 11 / 12 for ISP1302-B5
66 #define TX_PIN_NUMBER 9 // UART TX pin number. Default 09 / 15 for ISP1302-B5
67 #define CTS_PIN_NUMBER 10 // CTS pin number. Default 10 / 0 for ISP1302-B5
68 #define RTS_PIN_NUMBER 8 // RTS pin number. Default 8 / 2 for ISP1302-B5
69 #define HWFC true
70
71 #define SPIS_MISO_PIN 28 // SPI MISO signal.
72 #define SPIS_CSN_PIN 12 // SPI CSN signal.
73 #define SPIS_MOSI_PIN 25 // SPI MOSI signal.
74 #define SPIS_SCK_PIN 29 // SPI SCK signal.
75

```

3. Click Build Target and Load.
4. If you have the next error message, it means that you have not enough RAM to flash algorithm.

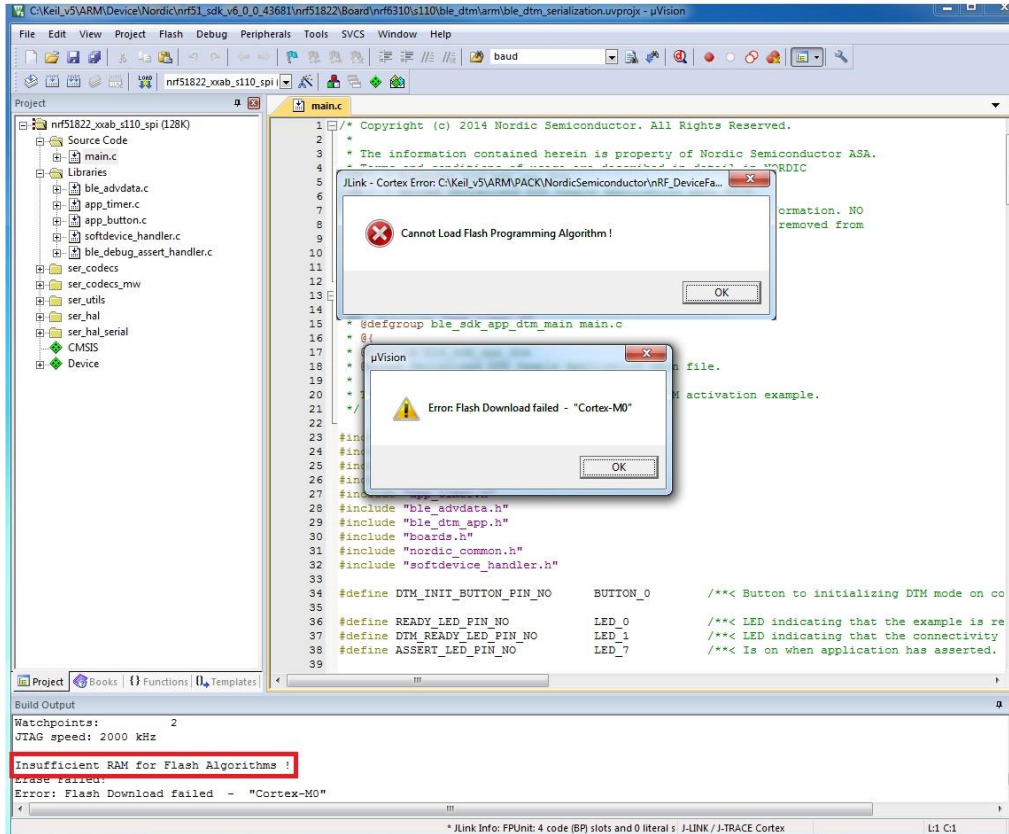

5. You can modify the size of the RAM Algorithm in :
Flash → *Configure Flash Tools...* and on the windows click on *Debug* → *Settings*
 Click on *Flash Download* and modify the size (put 0x02000).

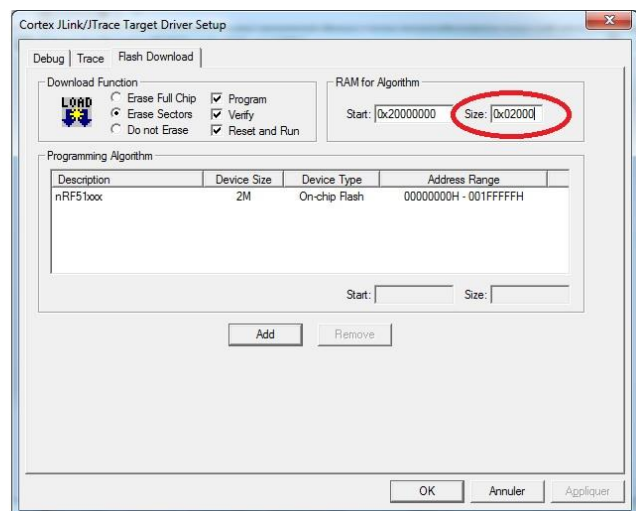
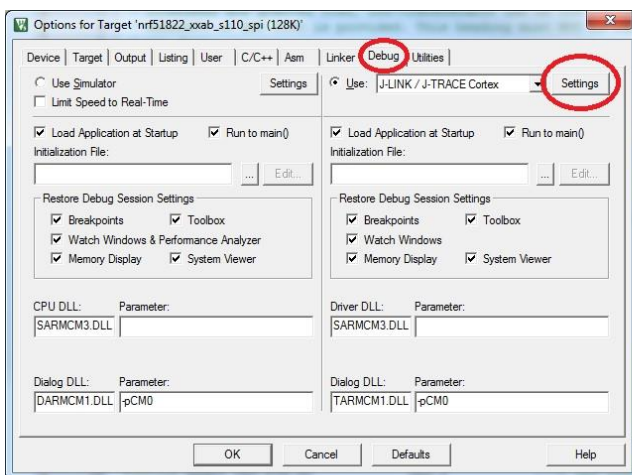

6. Click OK and load again the project.

Direct Test Mode Testing

1. Start nRFgo Studio.
2. Select Direct Test Mode.

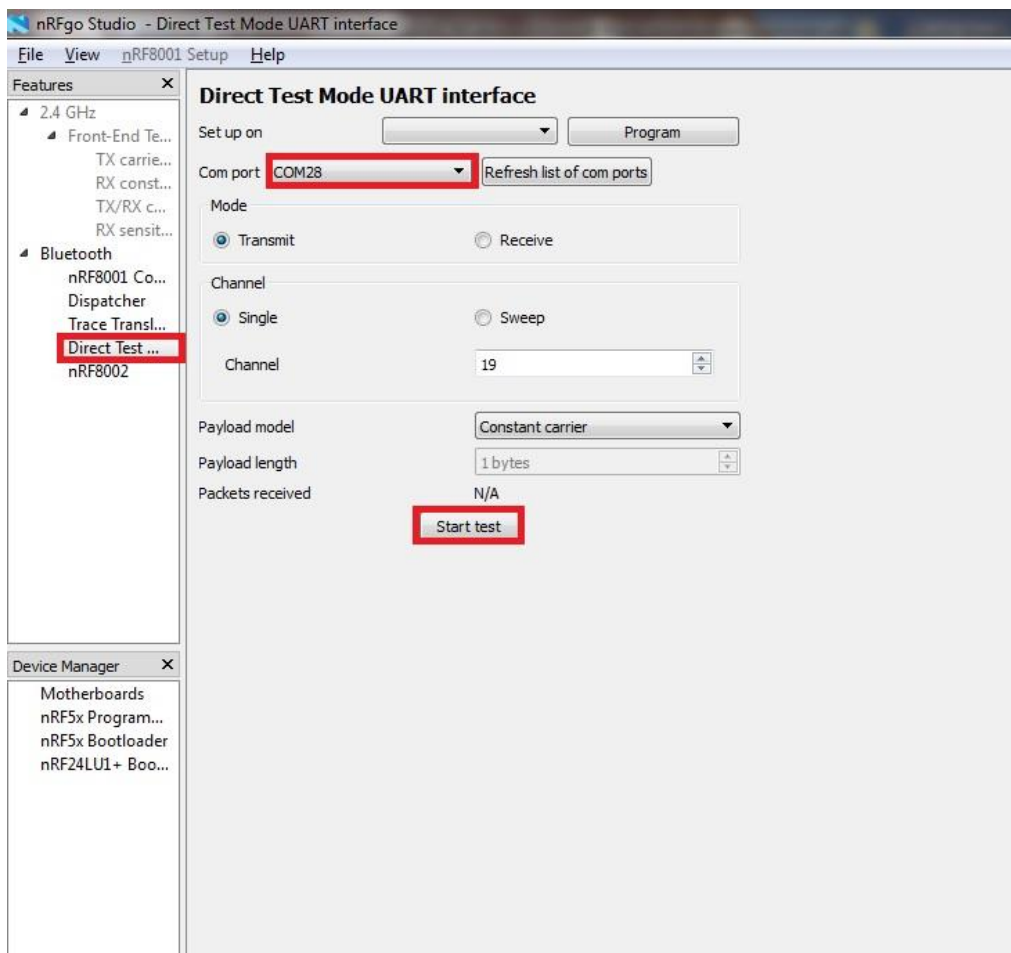

3. For details on how to use the Direct Test Mode, press F1 to open the nRFgo Studio help.

Important notification: Erase all before loading Direct Test Mode program. The SoftDevice must not be loaded, only the Program Application with uvision or with nRFgo studio in "Program Application" (load the .hex generated by uvision).

5.3. UART Mode Example

This paragraph shows you how to set up and program a communication by sending some characters through the UART interface on ISP130301-xx-TB Test Board. This example just echoes input characters from the PC terminal.

UART Mode Set-up

1. Connect the USB cable from the Interface Board ISP130603 to your computer.
2. Connect the ISP130301-xx-TB Test Board to the ISP130603 Interface Board with the 10 pin, 14 pin and 22 pin FPC jumper cables (0.5 mm pitch, provided in the Development Kit)
3. On the ISP130603 Interface Board, connect the 2-lead patch cable in order to connect:
 - RXD to P0_11
 - TXD to P0_09
 - CTS to P0_10
 - RTS to P0_08

Make sure the RXD/TXD and CTS/RTS labels match for each wire. This matches the default setting if you are using the Nordic Board pca10028 in the SDK project (be careful: depending on the Nordic Board version you are using, the ports used could be different, see next part: UART Mode loading). CTS and RTS are needed because in the UART process when the TX is ready to send (RTS), the RX needs to allow the TX send datas (CTS) and vice versa.

UART Mode Loading

1. Start Keil uVision.
2. Select Project then Open Project in order to open UART_example application:
C:\Keil_v5\ARM\Pack\NordicSemiconductor\nRF_Examples\10.0.0\peripheral\uart\pca10028\arm5\uart_pca10028.uvprojx.

Warning: Regarding the Nordic Board you are using, the associate pin number could be different. In the following pictures, the Nordic board PCA10028 is used and by default:

- RXD to P0_11
- TXD to P0_09
- CTS to P0_10 // If you use the interface board ISP130603 Version C or older, put a jumper between CTS and P0_08
- RTS to P0_08 // If you use the interface board ISP130603 Version C or older, put a jumper between RTS and P0_10

(The CTS and RTS are inversed in the ISP130603 schematic).

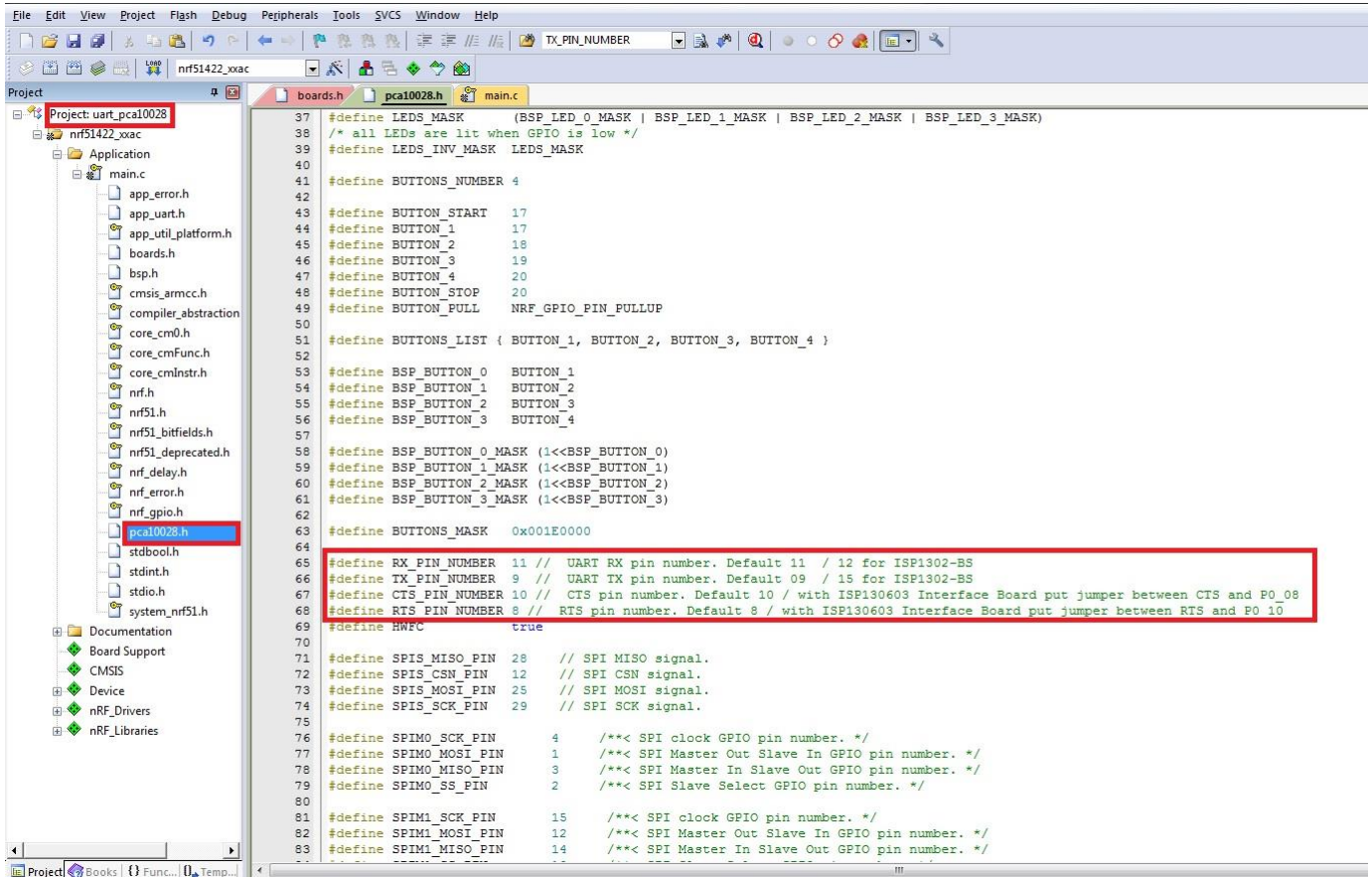

```

37 #define LEDS_MASK (BSP_LED_0_MASK | BSP_LED_1_MASK | BSP_LED_2_MASK | BSP_LED_3_MASK)
38 /* all LEDs are lit when GPIO is low */
39 #define LEDS_INV_MASK LEDS_MASK
40
41 #define BUTTONS_NUMBER 4
42
43 #define BUTTON_START 17
44 #define BUTTON_1 17
45 #define BUTTON_2 18
46 #define BUTTON_3 19
47 #define BUTTON_4 20
48 #define BUTTON_STOP 20
49 #define BUTTON_PULL NRF_GPIO_PIN_PULLUP
50
51 #define BUTTONS_LIST { BUTTON_1, BUTTON_2, BUTTON_3, BUTTON_4 }
52
53 #define BSP_BUTTON_0 BUTTON_1
54 #define BSP_BUTTON_1 BUTTON_2
55 #define BSP_BUTTON_2 BUTTON_3
56 #define BSP_BUTTON_3 BUTTON_4
57
58 #define BSP_BUTTON_0_MASK (1<<BSP_BUTTON_0)
59 #define BSP_BUTTON_1_MASK (1<<BSP_BUTTON_1)
60 #define BSP_BUTTON_2_MASK (1<<BSP_BUTTON_2)
61 #define BSP_BUTTON_3_MASK (1<<BSP_BUTTON_3)
62
63 #define BUTTONS_MASK 0x001E0000
64
65 #define RX_PIN_NUMBER 11 // UART RX pin number. Default 11 / 12 for ISP1302-B5
66 #define TX_PIN_NUMBER 9 // UART TX pin number. Default 09 / 15 for ISP1302-B5
67 #define CTS_PIN_NUMBER 10 // CTS pin number. Default 10 / with ISP130603 Interface Board put jumper between CTS and P0_08
68 #define RTS_PIN_NUMBER 8 // RTS pin number. Default 8 / with ISP130603 Interface Board put jumper between RTS and P0_10
69 #define HWFC true
70
71 #define SPIS_MISO_PIN 28 // SPI MISO signal.
72 #define SPIS_CSN_PIN 12 // SPI CSN signal.
73 #define SPIS_MOSI_PIN 25 // SPI MOSI signal.
74 #define SPIS_SCK_PIN 29 // SPI SCK signal.
75
76 #define SPIMO_SCK_PIN 4 /**< SPI clock GPIO pin number. */
77 #define SPIMO_MOSI_PIN 1 /**< SPI Master Out Slave In GPIO pin number. */
78 #define SPIMO_MISO_PIN 3 /**< SPI Master In Slave Out GPIO pin number. */
79 #define SPIMO_SS_PIN 2 /**< SPI Slave Select GPIO pin number. */
80
81 #define SPIM1_SCK_PIN 15 /**< SPI clock GPIO pin number. */
82 #define SPIM1_MOSI_PIN 12 /**< SPI Master Out Slave In GPIO pin number. */
83 #define SPIM1_MISO_PIN 14 /**< SPI Master In Slave Out GPIO pin number. */

```

3. Click Build Target and Load.

UART Mode Testing

1. Download and install the program "Putty.exe" (or equivalent like TTERM for example) in order to configure the baudrate, the port COM, .. etc ...

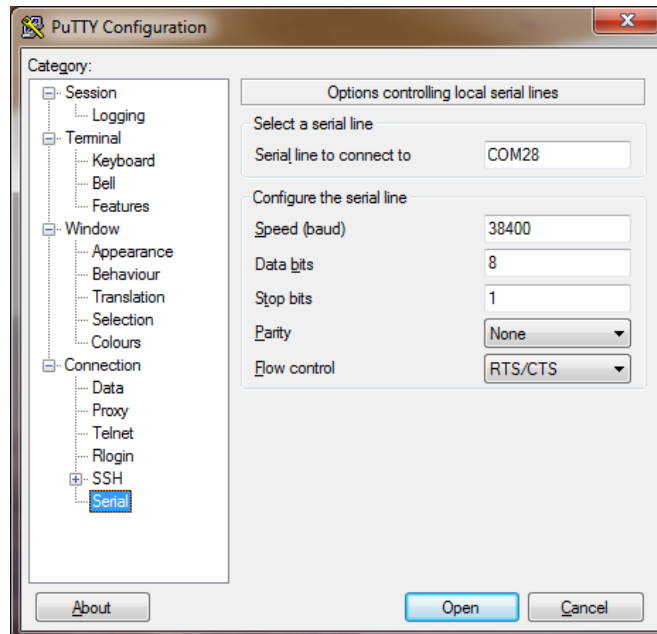

2. Click to Open.
3. You can write and/or delete some characters. Sometimes you have to reset the ISP130603 Interface Board in case if it is not working.

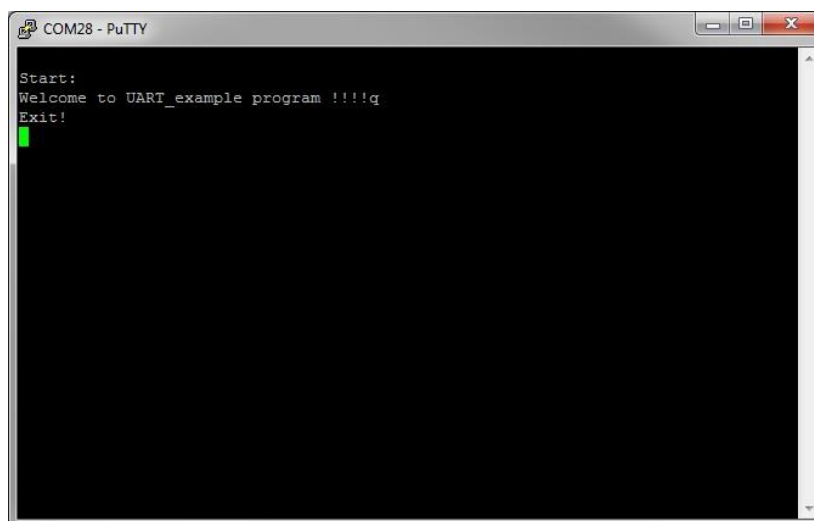

4. Press 'q' to exit

5.4. BLE UART Mode Example

This paragraph shows you how to set up and program an example that emulates a serial port over BLE. In the example, Nordic Semiconductor's development board serves as a peer to the phone application "nRF UART", which is available for iOS from Apple Store and for Android from Play Store. In addition, the example demonstrates how to use a proprietary (vendor-specific) service and characteristics with the SoftDevice. In order to use Bluetooth Low Energy and UART interface, the software is loaded in 2 parts:

- one of the following SoftDevices: **S110, S130, S132**.
- ble_app_uart using Keil uVision.

UART Mode Set-up

1. Connect the USB cable from the Interface Board ISP130603 to your computer.
2. Connect the ISP130301-xx-TB Test Board to the ISP130603 Interface Board with the 10 pin, 14 pin and 22 pin FPC jumper cables (0.5 mm pitch, provided in the Development Kit)
3. On the ISP130603 Interface Board, connect the 2-lead patch cable in order to connect:
 - RXD to P0_11
 - TXD to P0_09
 - CTS to P0_10
 - RTS to P0_08

Make sure the RXD/TXD and CTS/RTS labels match for each wire (be careful: depending on the Nordic Board version you are using, the ports used could be different, see next part: UART Mode loading).

CTS and RTS are needed because in the UART process when the TX is ready to send (RTS), the RX needs to allow the TX send datas (CTS) and vice versa.

S1XX SoftDevice loading

1. Start nRFgo Studio
2. Select nRF5x Programming
3. Click Erase all
4. Browse to SoftDevice hex file and click Program. The SoftDevice is available on the Nordic Website or by installing the SoftDevice with the Pack Installer, for example:
C:\Keil_v5\ARM\Pack\NordicSemiconductor\nRF_SoftDevice_S110\8.0.3\hex
We are using the S110 in this example.

UART Mode Loading

1. Start Keil uVision.
2. Select Project then Open Project in order to open ble_app_uart application:
C:\Keil_v5\ARMPack\NordicSemiconductor\NRF_Examples\10.0.0\ble_peripheral\ble_app_uart\pca10028\s110\arm5\ble_app_uart_s110_pca10028.

Warning: Regarding the Nordic Board you are using, the associate pin number could be different. In the following pictures, the Nordic board PCA10028 is used and we changed the default values:

- RXD to P0_11
- TXD to P0_09
- CTS to P0_10 // If you use the interface board ISP130603 Version C or older, put a jumper between CTS and P0_08
- RTS to P0_08 // If you use the interface board ISP130603 Version C or older, put a jumper between RTS and P0_10

(The RTS and CTS are inversed in the ISP130603 schematic).

3. Click Build Target and Load.

Insight SiP can provide the Hex files on demand at contact@insightsip.com

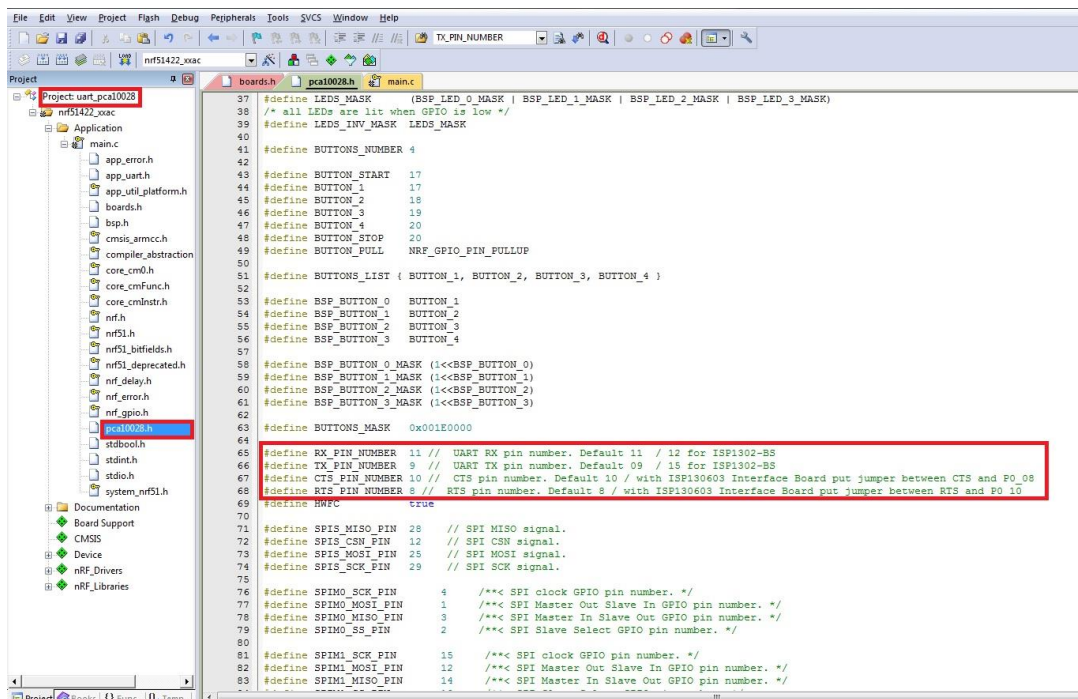

```

37 #define LEDS_MASK (BSP_LED_0_MASK | BSP_LED_1_MASK | BSP_LED_2_MASK | BSP_LED_3_MASK)
38 /* all LEDs are lit when GPIO is low */
39 #define LEDS_INT_MASK LEDS_MASK
40
41 #define BUTTONS_NUMBER 4
42
43 #define BUTTON_START 17
44 #define BUTTON_1 17
45 #define BUTTON_2 18
46 #define BUTTON_3 19
47 #define BUTTON_4 20
48 #define BUTTON_STOP 20
49 #define BUTTON_PULL NRF_GPIO_PIN_PULLUP
50
51 #define BUTTONS_LIST { BUTTON_1, BUTTON_2, BUTTON_3, BUTTON_4 }
52
53 #define BSP_BUTTON_0 BUTTON_1
54 #define BSP_BUTTON_1 BUTTON_2
55 #define BSP_BUTTON_2 BUTTON_3
56 #define BSP_BUTTON_3 BUTTON_4
57
58 #define BSP_BUTTON_0_MASK (1<<BSP_BUTTON_0)
59 #define BSP_BUTTON_1_MASK (1<<BSP_BUTTON_1)
60 #define BSP_BUTTON_2_MASK (1<<BSP_BUTTON_2)
61 #define BSP_BUTTON_3_MASK (1<<BSP_BUTTON_3)
62
63 #define BUTTONS_MASK 0x001E0000
64
65 #define RX_PIN_NUMBER 11 // UART RX pin number. Default 11 / 12 for ISP1302-B5
66 #define TX_PIN_NUMBER 9 // UART TX pin number. Default 09 / 15 for ISP1302-B5
67 #define CTS_PIN_NUMBER 10 // CTS pin number. Default 10 // with ISP130603 Interface Board put jumper between CTS and P0_08
68 #define RTS_PIN_NUMBER 8 // RTS pin number. Default 8 // with ISP130603 Interface Board put jumper between RTS and P0_10
69 #define HWFC true
70
71 #define SPIS_MISO_PIN 28 // SPI MISO signal.
72 #define SPIS_CSN_PIN 12 // SPI CSN signal.
73 #define SPIS_MOSI_PIN 25 // SPI MOSI signal.
74 #define SPIS_SCK_PIN 29 // SPI SCK signal.
75
76 #define SPIMO_SCK_PIN 4 /**< SPI clock GPIO pin number. */
77 #define SPIMO_MOSI_PIN 1 /**< SPI Master Out Slave In GPIO pin number. */
78 #define SPIMO_MISO_PIN 3 /**< SPI Master In Slave Out GPIO pin number. */
79 #define SPIMO_SS_PIN 2 /**< SPI Slave Select GPIO pin number. */
80
81 #define SPIM1_SCK_PIN 15 /**< SPI clock GPIO pin number. */
82 #define SPIM1_MOSI_PIN 12 /**< SPI Master Out Slave In GPIO pin number. */
83 #define SPIM1_MISO_PIN 14 /**< SPI Master In Slave Out GPIO pin number. */

```

BLE Mode Testing

1. Download and install "nRF UART" on your iOS or Android device, which is available for iOS from Apple Store and for Android from Play Store.
2. Run the App, click to Connect and select the device: Nordic_UART.

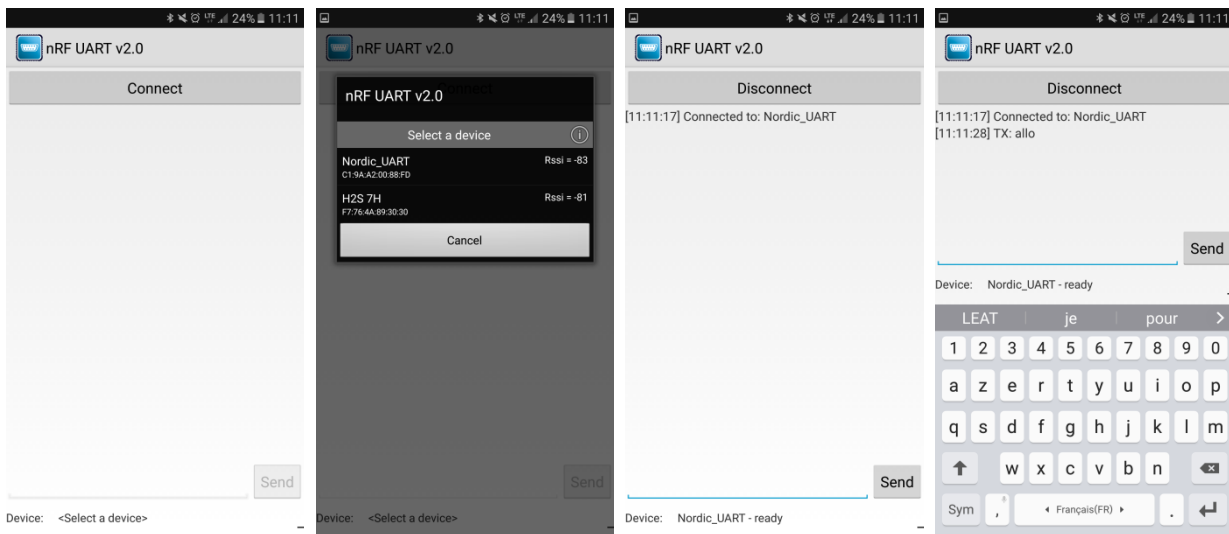

3. You are now able to send and receive data through the BLE. Next step is to establish the communication with the UART interface.

UART Mode Testing

1. Download and install the program "RealTerm" (or equivalent like Putty, TTERM for example) in order to configure the baudrate, the port COM, .. etc ...

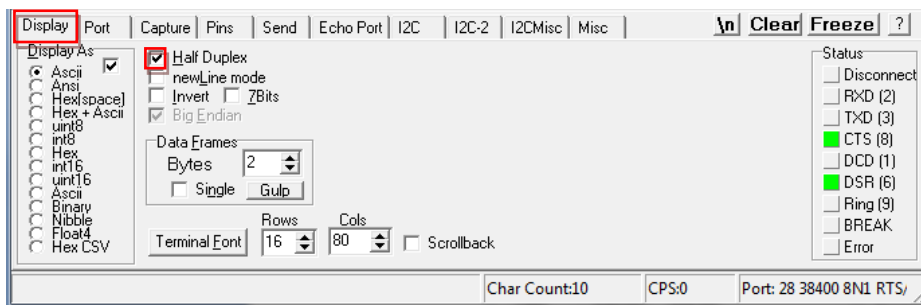

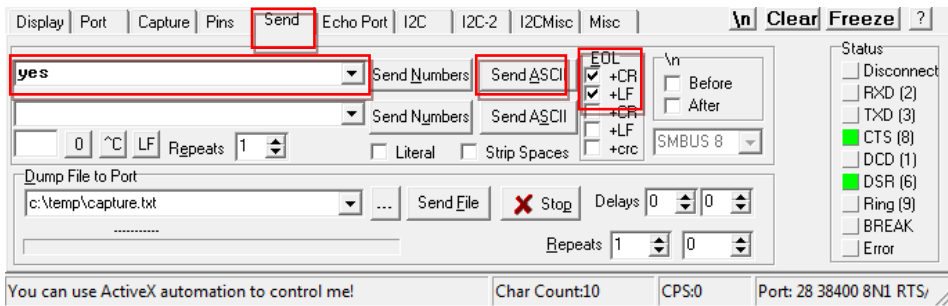
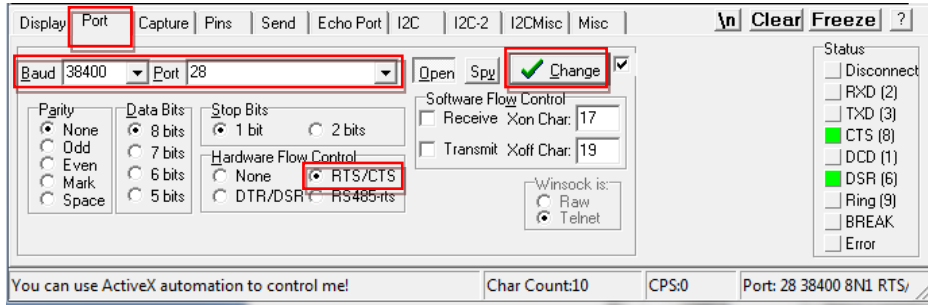

2. Click to Send, write some characters and click to “Send ASCII”.

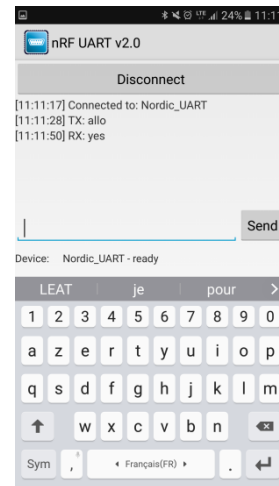
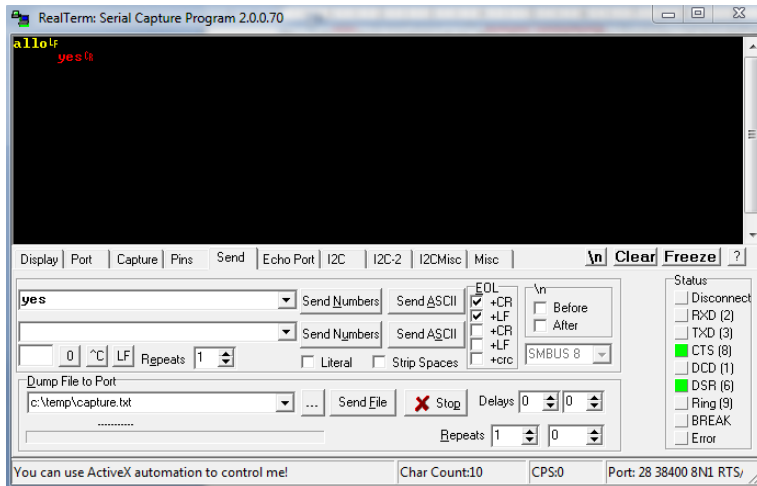

3. The communication is established, you are now able to emulate a serial port over BLE.

6. Basic Sensor Application with ISP131001

This paragraph shows you how to set up a Sensor application with ISP131001 Sensors Board that will send data via the Bluetooth link to the Master Emulator or to an Apple Device.

Two types of demonstration are presented. The first one is directly executable with hardware and software provided in the Development Kit using Master Control Panel application. The second demonstration requires the use of an iPhone or an iPad. The iOS application is available on the App Store.

6.1. On Master Control Panel

1. Place the CR2032 lithium battery into the battery holder.
2. Connect nRF51 Dongle (Master Emulator) into a USB port on your computer.
3. Start Master Control Panel.
4. Click Start Discovery.

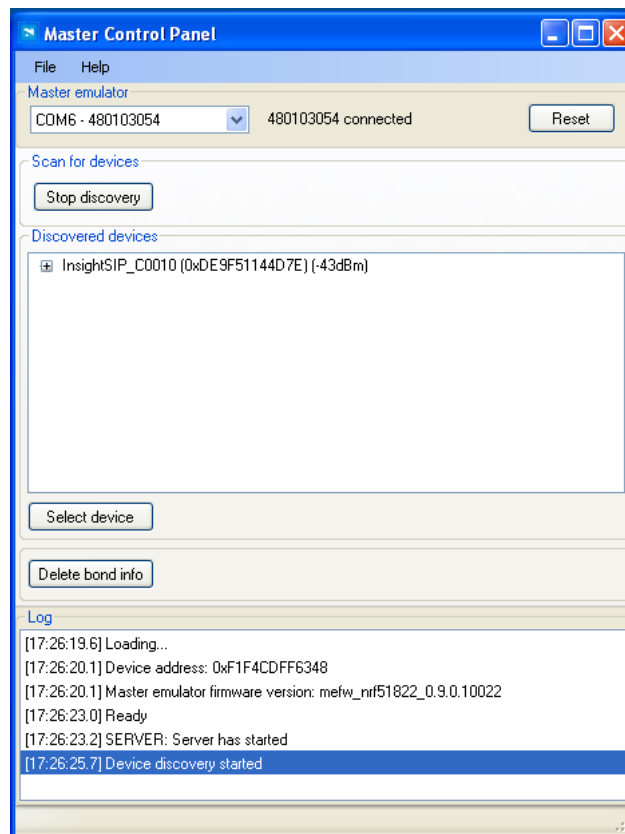

5. Click Select Device.
6. On the following display, click successively on Bond, Discover Services and Enable Services.

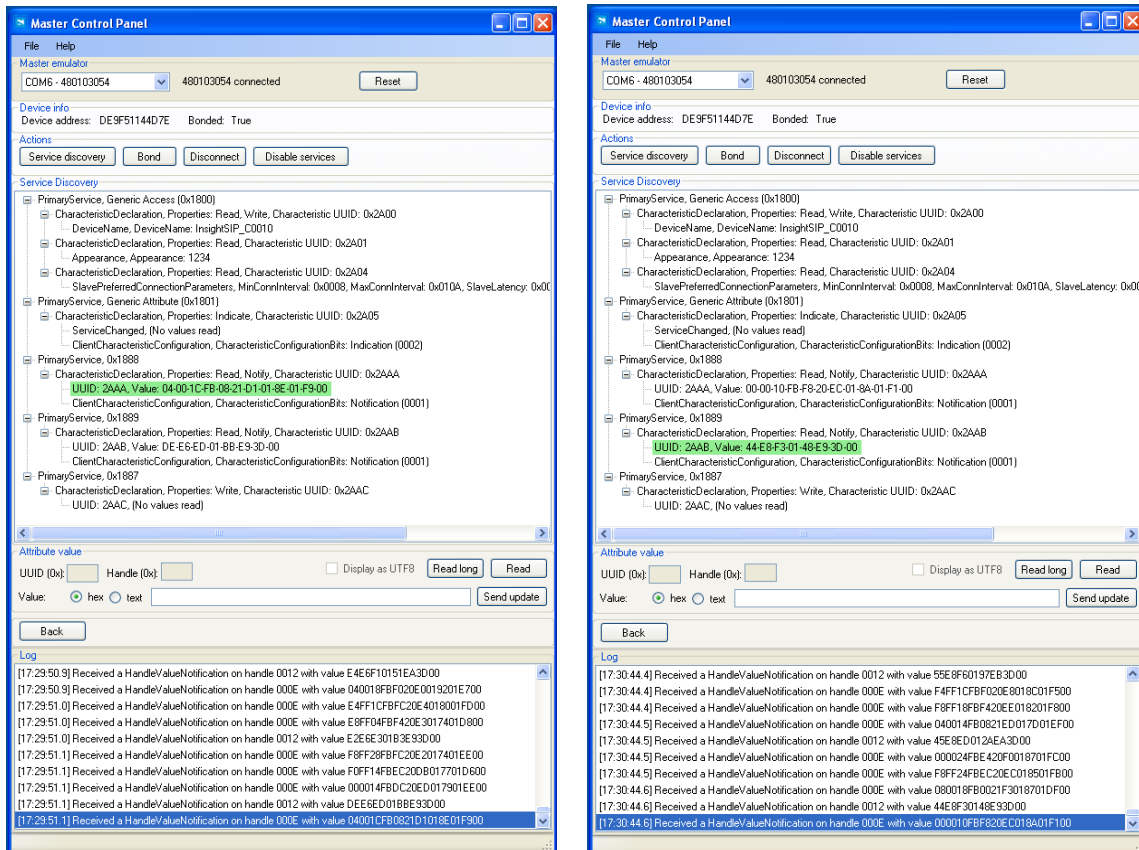

7. You can note data that transit between the ISP131001 Sensors Board and the Master Emulator via the Bluetooth link:
 - Data of the accelerometer/magnetometer on the above left figure
 - Data of the temperature/pressure on the above right figure
8. To switch off ISP131001 Sensors Board, remove battery.

6.2. On iPhone or iPad Device

The Sensor application is only available on iOS device. On the App Store, search “sip sensor” or “insight sip” and download the App. The iOS App is a demonstration App that is provided "as is" in order to demonstrate the Smart Bluetooth sensor node. Only one iPhone or iPad is allowed per development kit.

Make sure you iOS device is compatible with Bluetooth 4.0 (iPhone 4S or higher, iPad Air, Mini, 3rd generation and above).

The “sip sensor” application is downloaded and installed. You should see the application on your iOS device.

Then you will be able to set up the application demonstration as follows:

1. Place the CR2032 lithium battery into the battery holder.
2. Connect the battery holder to the Sensors Board ISP131001.
3. Start “isp sensor” application on your iOS, click Connect and select your Sensors Board.

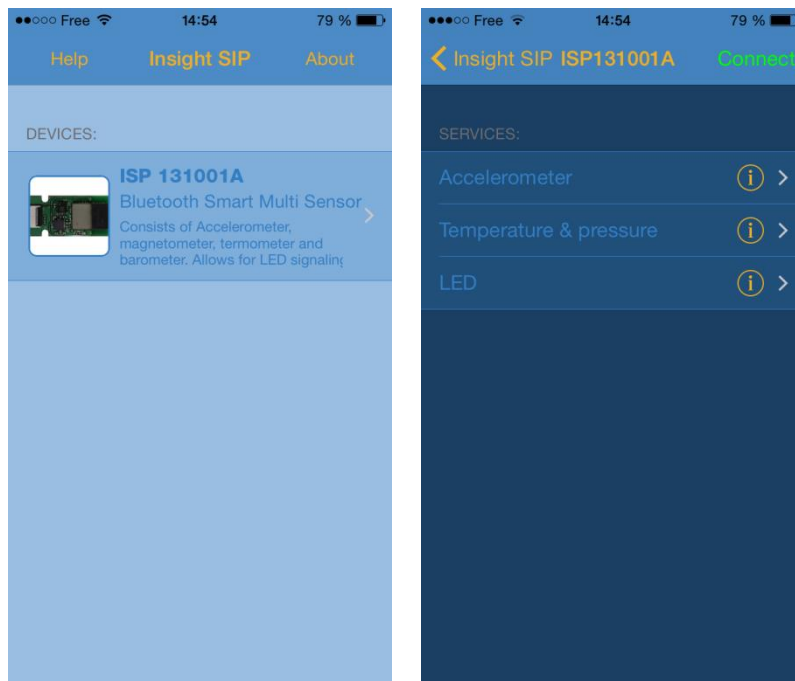

- Click Accelerometer. A Calibration phase invites you to rotate the ISP131001 Sensors Board. Then, a starship on your iPhone screen follows the Sensors board movement.

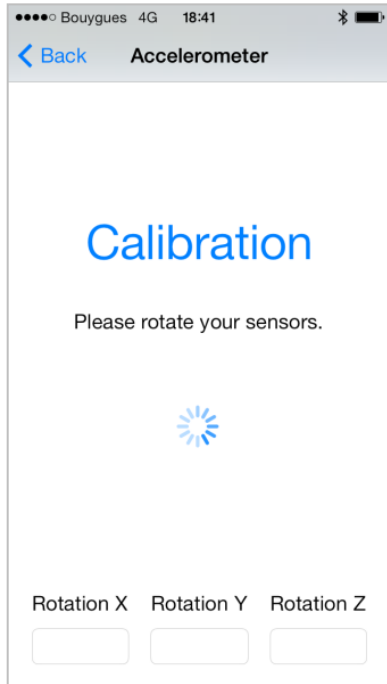

- Click Back and Temperature to start temperature and pressure demonstration.

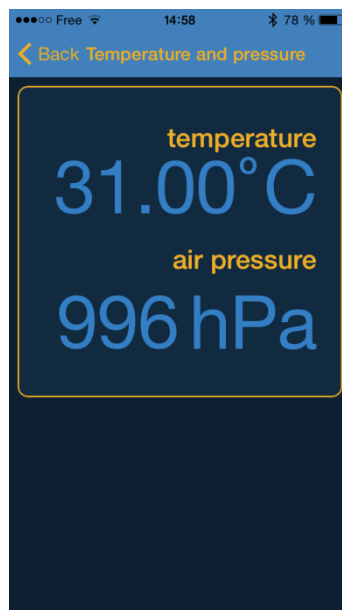

- Click Back and LED. A prompt will invite you to pair the Sensors Board with the iPhone. Click Pair. The LED lights up.

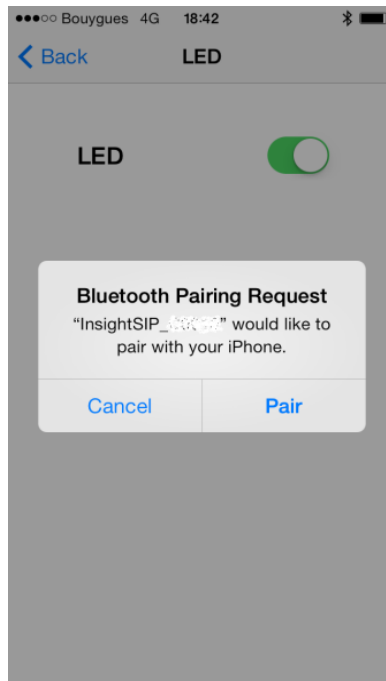

To switch off ISP131001 Sensors Board, remove battery.

6.3. On Android Device

An App is also available for Android Devices. On Google Play, search “sip sensor” or “insight sip” and download the App. The android App is a demonstration App that is provided “as is” in order to demonstrate the Smart Bluetooth sensor node.

Make sure your Android device is compatible with Bluetooth 4.0 (Android v4.3 at least).

After the “sip sensor” application is downloaded and installed you should see the application on your Android device. Then you will be able to set up the application demonstration as follows:

- (For Android v6 or earlier) In order to be able to scan for BLE devices, the application needs to have “Location” permission. You have to enable “Location” service in the settings and give permission to the Sensor App to use Location (Settings -> Application Manager -> Sensor -> Permission).
- Place the CR2032 lithium battery into the battery holder.
- Start “Sensor” application on your Android, click Connect and select your Sensor Board (InsightSIP_DEMO)

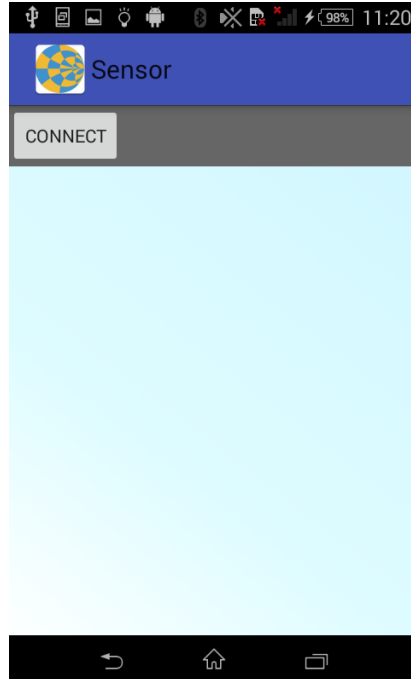

4. A Calibration phase invites you to rotate the ISP131001 Sensors Board. Then, a menu will appear.

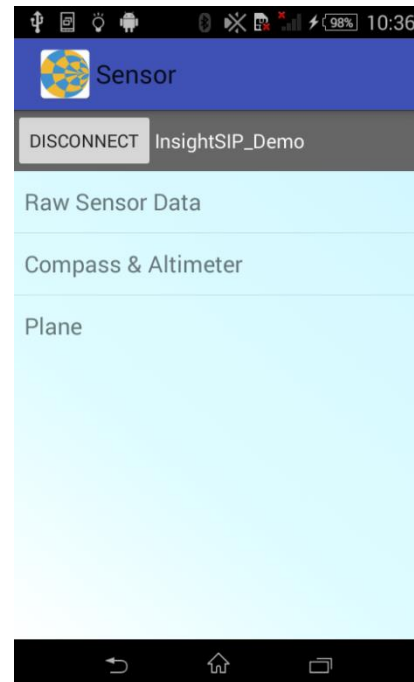
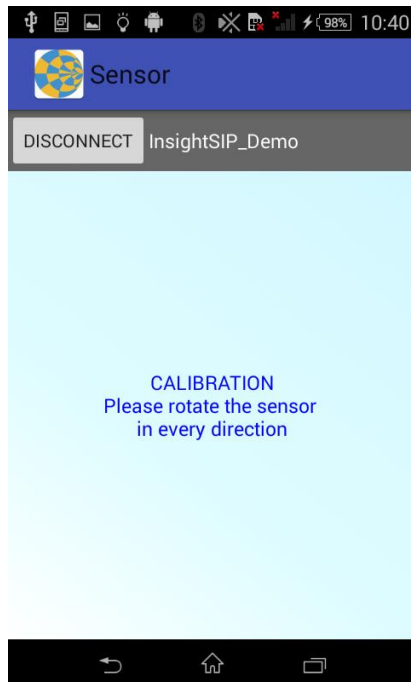

5. Select "Plane" and a plane will appear on the screen and it will follow the board movement.

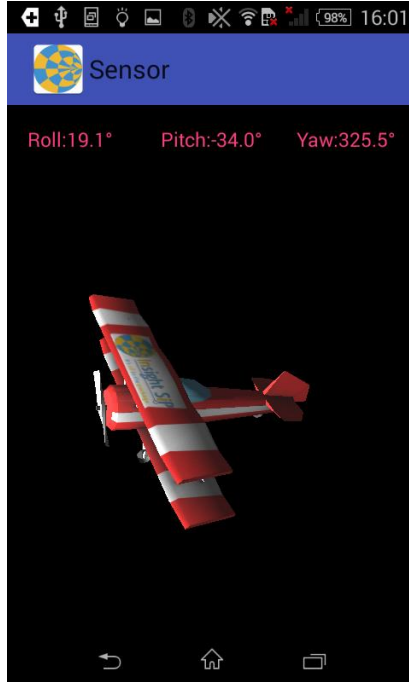

6. Press Back and Select "Raw Sensor Data" to monitor all sensor data. On this screen, LED can also be turned ON/OFF.

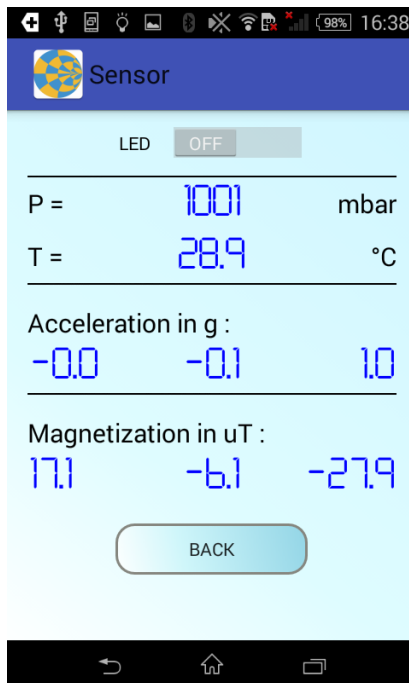

7. Press Back and Select "Compass & Altimeter". The top part is the altimeter, it has to be calibrated by entering your current altitude once. The bottom part is the compass and it doesn't need to be calibrated (it has already been done in step 4).

