

ISP1507

High Performance Bluetooth 5 Ready, NFC* & ANT Low Energy Module with MCU & Antenna

This ultra-small LGA module, 8 x 8 x 1 mm, is based on the nRF52 Chip. Its powerful Cortex™ M4 CPU, flash and RAM memory combined with an optimized antenna offers the perfect solution for Bluetooth connectivity. The solution is best in class for RF performance and low power consumption. Multiple digital and analogue interfaces give optimum flexibility for sensor integration.

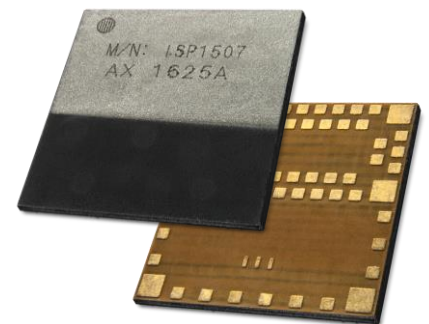

Key Features

- Multi-protocol 2.4GHz Ultra Low Power RF Transceiver
- Bluetooth 5-Ready stack
ANT/ANT+ stack
2.4 GHz proprietary stack
- (*) NFC-A Tag for OOB pairing in option
- Fully integrated RF matching and Antenna
- Integrated 32 MHz & 32kHz Clock
- DC/DC converter with loading circuit
- Based on Nordic Semiconductor nRF52
- 32-bit ARM Cortex M4 CPU
- 512 kB Flash and 64 kB SRAM
or 192 kB Flash and 24 kB SRAM versions
- From 13 to 30 configurable GPIOs including up to 3 to 8 ADC
- Many interfaces SPI, UART, PDM, I2C
- Single 1.7 to 3.6 V supply
- Very small size 8.0 x 8.0 x 1.0 mm
- Temperature -40 to +85 °C

Applications

- Connected sensors for medical devices, healthcare, sport, fitness, industrial ...
- IoT applications, connected objects
- Wearable technology
- Home automation
- Beacons

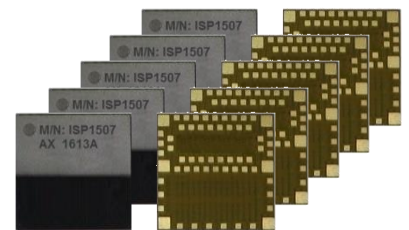

Certifications

- Fully FCC certified module
- Fully CE certified module
- Fully IC certified module
- Fully TELEC certified module
- Bluetooth SIG certified QDL listing
- RoHS compliant

Contents

1.	Block Diagram	3
2.	Specifications	4
2.1.	General Notice	4
2.2.	Absolute Maximum Ratings	4
2.3.	Operating Conditions	4
2.4.	Power Consumption	5
2.5.	Clock Sources	5
2.6.	Radio Specifications	5
2.7.	Electrical Schematic	8
3.	Pin Description	10
4.	Mechanical Outlines	13
4.1.	Mechanical Dimensions	13
4.2.	SMT Assembly Guidelines	14
4.3.	Antenna Keep-Out Zone	14
5.	Product Development Tools.....	15
5.1.	Hardware	15
5.2.	Firmware	15
5.3.	Development Tools.....	16
6.	Reference Designs	17
6.1.	Beacon Design	17
6.2.	Sensor Board Design	18
7.	Packaging & Ordering information.....	21
7.1.	Marking	21
7.2.	Prototype Packaging	21
7.3.	Jedec Trays.....	21
7.4.	Tape and Reel.....	22
7.5.	Ordering Information.....	23
8.	Storage & Soldering information	24
8.1.	Storage and Handling	24
8.2.	Moisture Sensitivity.....	24
8.3.	Soldering information.....	25
9.	Quality & User information	26
9.1.	Certifications	26
9.2.	USA – User information	26
9.3.	Canada – User information	26
9.4.	RF Exposure Information	27
9.5.	Informations concernant l'exposition aux fréquences radio (RF)	27
9.6.	Discontinuity	27
9.7.	Disclaimer	28

1. Block Diagram

This module is based on nRF52 Nordic Semiconductor 2.4GHz wireless System on Chip (SoC) integrating a 2.4 GHz transceiver, a 32-bit ARM Cortex™-M4 CPU, either 512 kB or 192 kB flash memory, either 64 kB RAM or 24 kB RAM and analog and digital peripherals.

It can support BLE, ANT/ANT+ and a range of proprietary 2.4 GHz protocols, such as Gazell from Nordic Semiconductor.

Fully qualified BLE stacks for nRF52 are implemented in the S112/S132 SoftDevices which can be freely downloaded. ISP1507 can then be used in Central, Peripheral or both roles for BLE and for both ends of other proprietary protocols. nRF52 platform also provides extensive software support for ANT applications with S212 SoftDevices and dual ANT/BLE stack S332 SoftDevices.

Ultra-low power consumption and advanced power management enables battery lifetimes up to several years on a coin cell battery. Even though its very small size 8 x 8 x 1.0 mm, the module integrates decoupling capacitors, 32 MHz and 32.768 kHz crystals, load capacitors, DC-DC converter, RF matching circuit and antenna in addition to the wireless SoC.

Only the addition of a suitable DC power source is necessary for BLE and/or ANT connectivity. Sensor applications require the further addition of appropriate sensors. The antenna was designed to be optimized with several standard ground plane sizes. When NFC function is available, the NFC tag antenna can be connected externally.

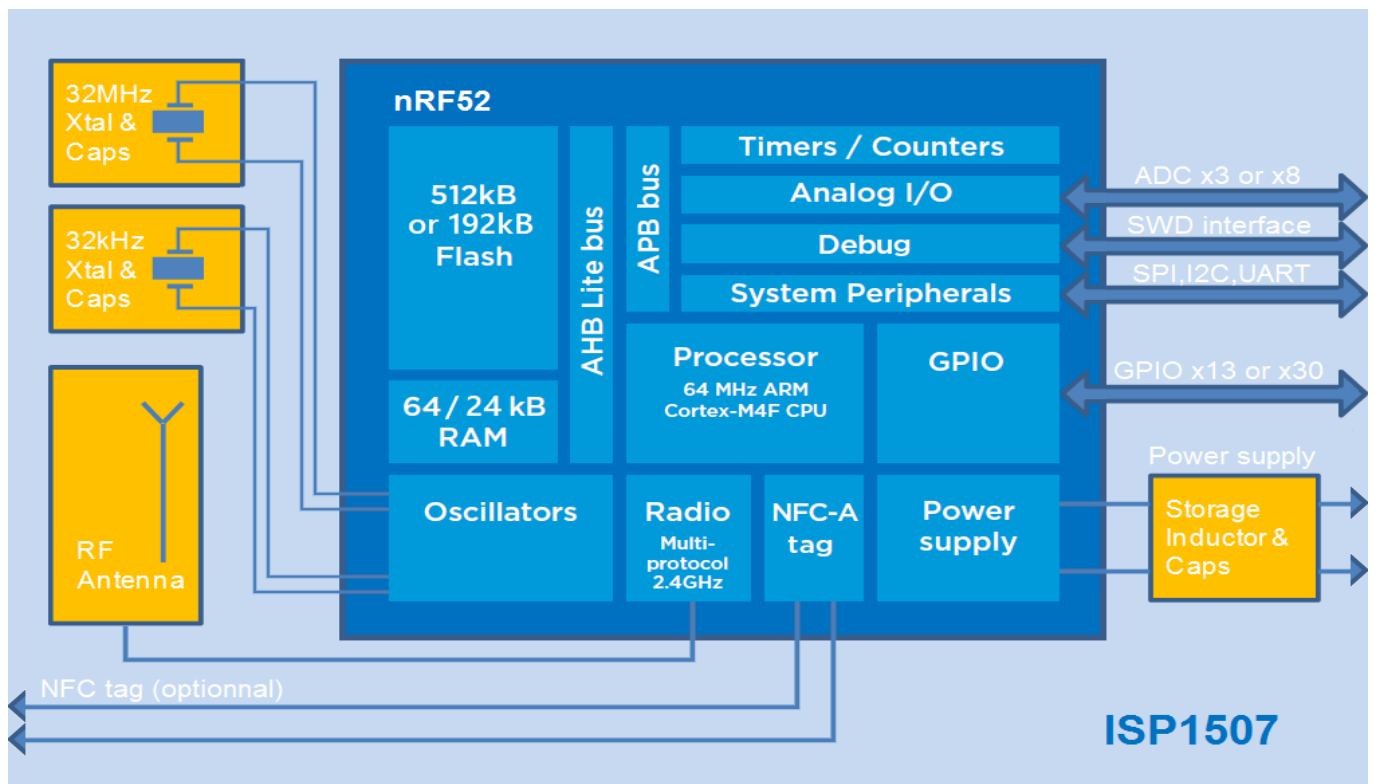

2. Specifications

2.1. General Notice

The electrical specifications of the module are directly related to the Nordic Semiconductor specifications for nRF52 chipset series. Bellow information is only a summary of the main parameters. For more detailed information, especially about current consumption, please refer to the up-to-date specification of the chipset available on Nordic Semi website.

2.2. Absolute Maximum Ratings

Parameter	Min	Typ	Max	Unit
Supply Voltage respect to ground - VCC	-0.3		3.9	V
IO Pin Voltage	-0.3		3.9	V
RF Input Level			10	dBm
NFC Antenna pin current			80	mA
Module Total Capacity			2.5	μF
Module Total Inductance			15	μH
Storage Temperature	-40		+125	°C
Moisture Sensitivity Level			3	-
ESD Human Body Model			4000	V
ESD Charged Device Model			750	V
Flash Endurance			10000	cycles



ATTENTION

CONSERVE PRECAUTIONFOR HANDLING
ELECTROSTATIC SENSITIVE DEVICES
Human Body Model Class 3A

2.3. Operating Conditions

Parameter	Min	Typ	Max	Unit
Operating Supply Voltage, independent of DCDC enable	1.7	3.0	3.6	V
Extended Industrial Operating Temperature Range	-40	+25	+85	°C

2.4. Power Consumption

Parameter	Typ / AL version	Typ / AX version	Unit
Peak current, Receiver active ⁽¹⁾	4.6	5.4	mA
Peak current, Transmitter active -40 dBm Output Power ⁽²⁾	3.4	4.1	mA
Peak current, Transmitter active 0 dBm Output Power ⁽²⁾	4.6	5.3	mA
System OFF, no RAM retention, wake on reset	0.3	0.3	µA
System ON, full RAM retention, wake on any event	1.5	1.9	µA
Additional RAM retention current per 4 KB block	40	40	nA

(1) DCDC enable, Power supply 3V, 1 Mbps

(2) DCDC enable, Power supply 3V

2.5. Clock Sources

Parameter	Max	Unit
Internal High Frequency Clock for RF Stability: 32 MHz Crystal Frequency Tolerance ⁽¹⁾	+/- 40	ppm
Internal Low Frequency Clock for BLE Synchronization: 32.768 kHz Crystal Frequency Tolerance ⁽¹⁾	+/- 40	ppm
Internal Low Frequency Clock for BLE Synchronization: RC Oscillator ⁽²⁾	+/- 250	ppm
RF Frequency tolerance: For BLE operation Channels0 to 39	+/- 40	ppm

(1) including initial tolerance, drift, aging, and frequency pulling

(2) Frequency tolerance after calibration

2.6. Radio Specifications

Parameter	Min	Typ	Max	Unit
Frequency Range	2402		2480	Mhz
Channel 0 to 39 Spacing		2		Mhz
Output Power Channels0 to 39	-20		+4	dBm
Rx sensitivity Level for BER <0,1% ideal Tx	-96			dBm
Antenna Gain		0.6		dBi
EIRP	-19.4		4.6	dBm
Range Open field @1m height		100		m
Data Rate	1000 / 2000			kbps

Typical Antenna Return Loss

Module mounted on a USB dongle ground plane

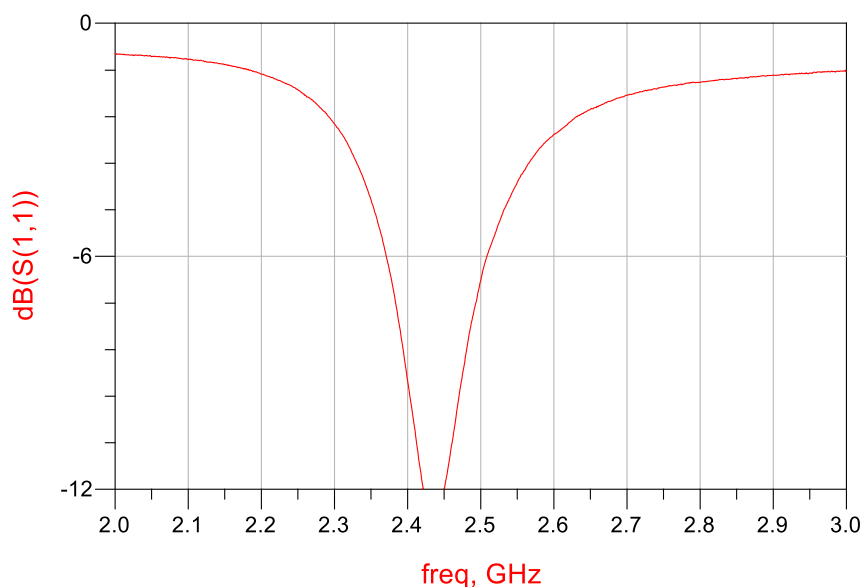

Radiation Pattern in 3 planes

Module mounted on a USB dongle ground plane

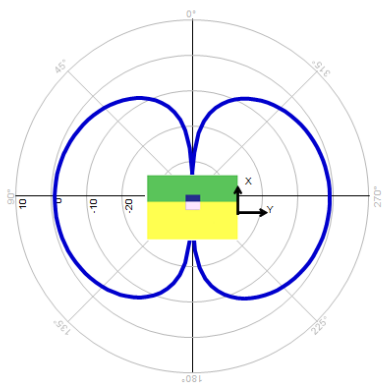
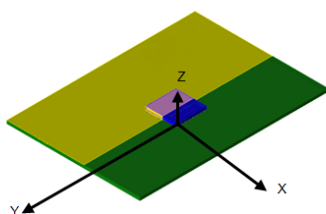

Phi (0.000 to 360.000)

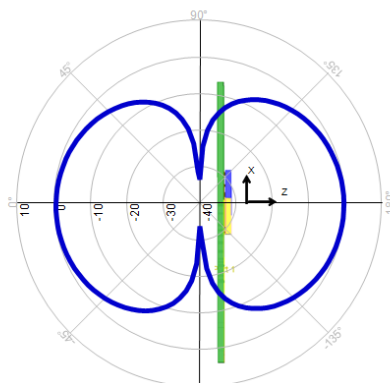

Thêta (-180.000 to 180.000)

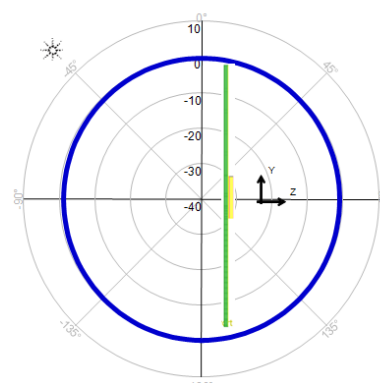

Thêta (-180.000 to 180.000)

Gain measurement in dBi @ 2.45 GHz.

Ground Plane Effect Simulation

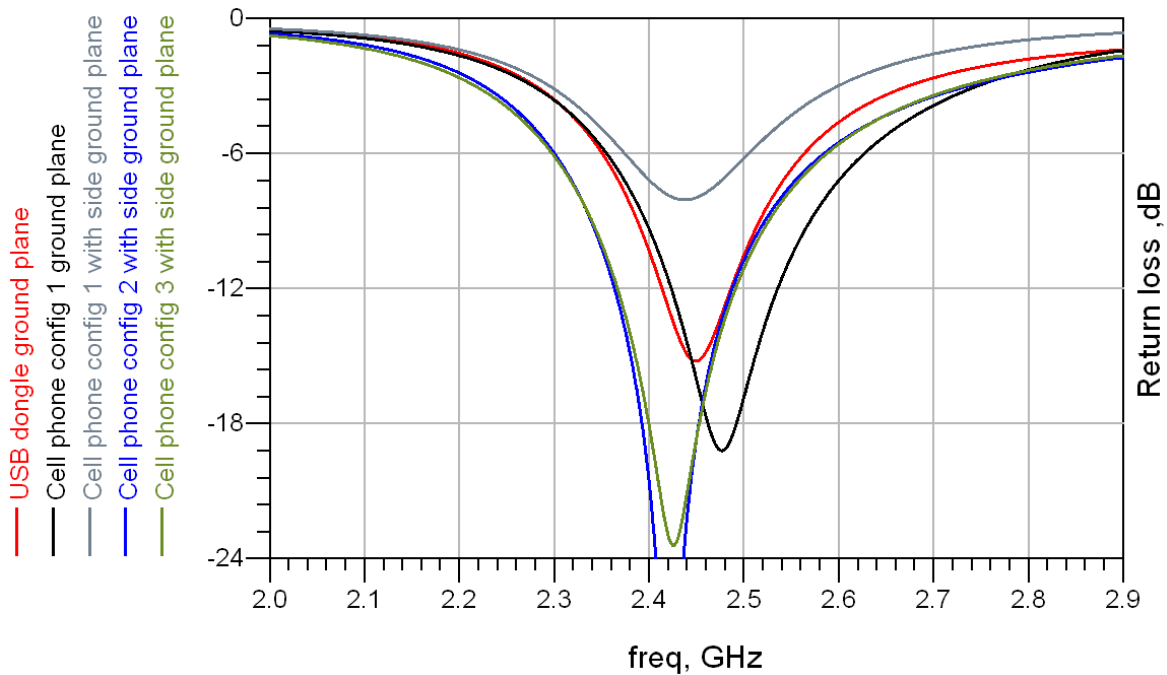
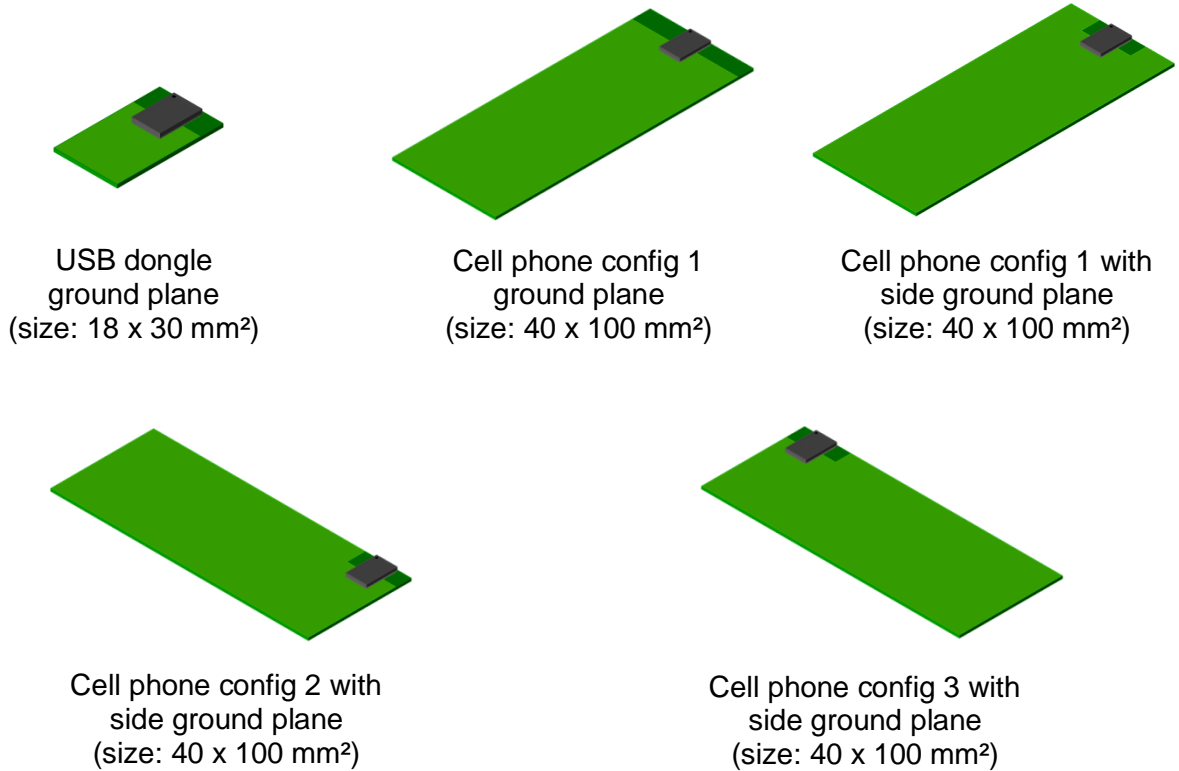

2.7. Electrical Schematic

AX version

Hereafter electrical schematic is showing ISP1507-AX module connections. For further information on electrical performance, please note that AX version is based on nRF52832-CIAA chipset.

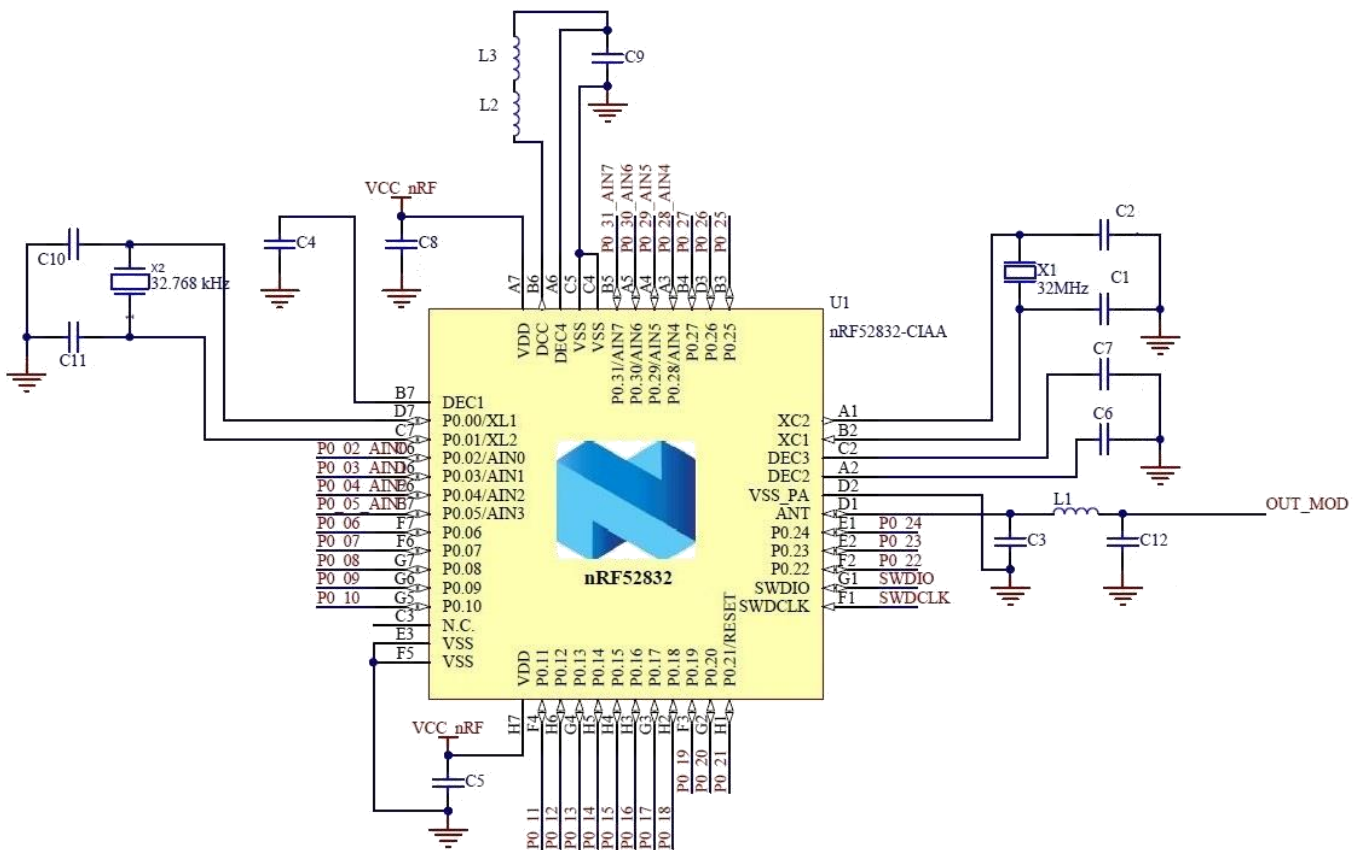

AL version

Hereafter electrical schematic is showing ISP1507-AL module connections. For further information on electrical performance, please note that AL version is based on nRF52810-CAAA chipset.

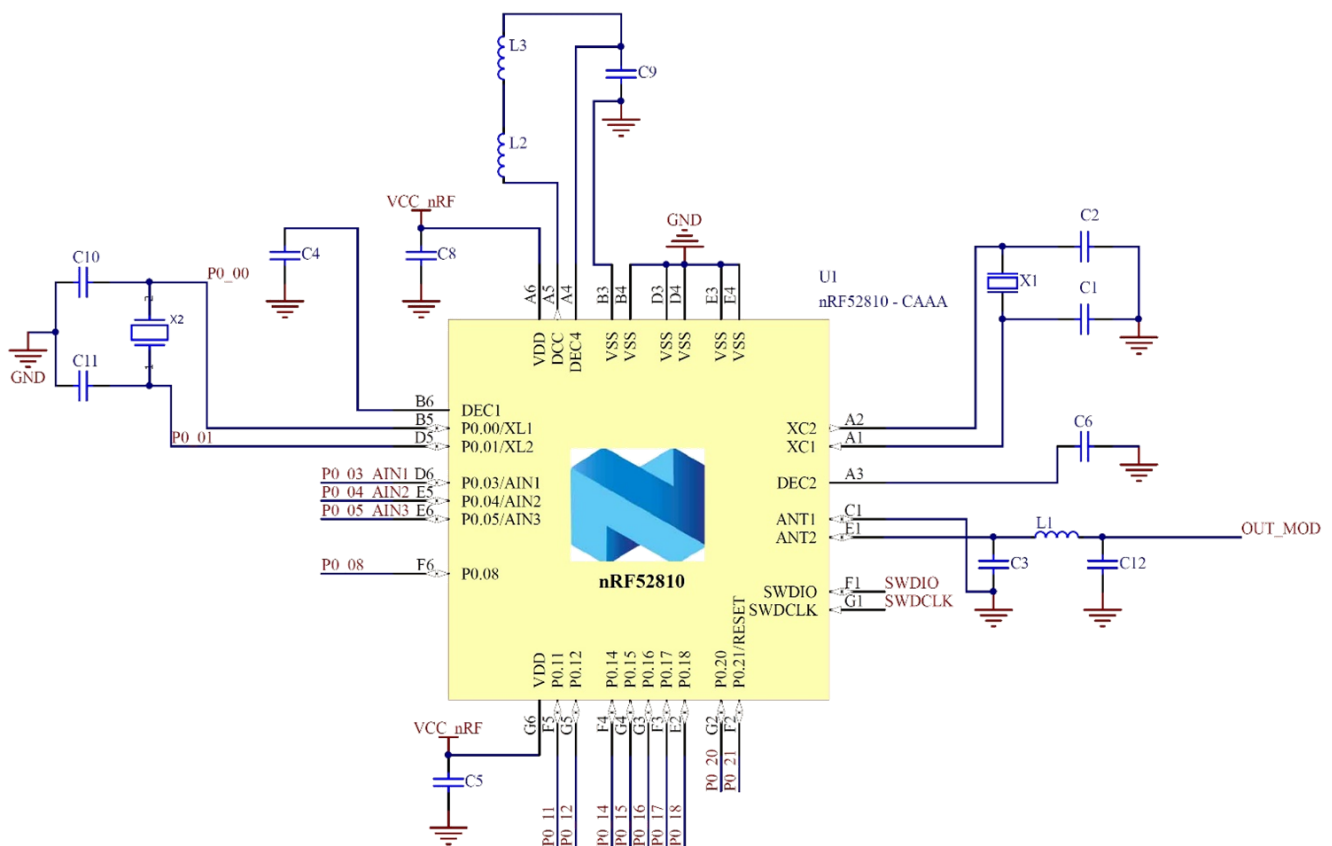

3. Pin Description

The module uses an LGA format with a double row of pads on a 0.65 mm pitch. The pad layout follows the QFN Jedec standard for 2 row LGA parts. The NC pads are to be connected to isolated metal pads on the application PCB for mechanical stability and reliability (drop test).

Pin & Type		Description for AX version		Description for AL version	
1	Ground	VSS	Must be connected to ground	VSS	Must be connected to ground
2	Digital I/O NFC Input	P0_09 NFC1	General purpose I/O pin NFC antenna connection	P0_12	General purpose I/O pin
3	Digital I/O	P0_12	General purpose I/O pin	NC	Isolated pad
4	Digital I/O NFC Input	P0_10 NFC2	General purpose I/O pin NFC antenna connection	P0_14 TRACE DATA3	General purpose I/O pin Trace port output
5	Digital I/O	P0_14 TRACE DATA3	General purpose I/O pin Trace port output	NC	Isolated pad
6	Digital I/O	P0_26	General purpose I/O pin	P0_18 TRACE DATA0	General purpose I/O pin Trace port output
7	Ground	VSS	Must be connected to ground	VSS	Must be connected to ground
8	Ground	VSS	Must be connected to ground	VSS	Must be connected to ground
9	Digital I/O	P0_16 TRACE DATA1	General purpose I/O pin Trace port output	P0_16 TRACE DATA1	General purpose I/O pin Trace port output
10	Ground	VSS	Must be connected to ground	VSS	Must be connected to ground
11	Digital I/O	P0_18 TRACE DATA0	General purpose I/O pin Trace port output	NC	Isolated pad
12	Ground	VSS	Must be connected to ground	VSS	Must be connected to ground
13	Digital I/O	P0_21 RESET	General purpose I/O pin Configurable as system RESET pin	P0_21 RESET	General purpose I/O pin Configurable as system RESET pin
14	Ground	VSS	Must be connected to ground	VSS	Must be connected to ground
15	Digital I/O	P0_20 TRACE CLK	General purpose I/O pin Trace port clock output	NC	Isolated pad
16	Ground	VSS	Must be connected to ground	VSS	Must be connected to ground
17	Digital I/O	P0_22	General purpose I/O pin	NC	Isolated pad
18	Ground	VSS	Must be connected to ground	VSS	Must be connected to ground
19	Digital I/O	P0_24	General purpose I/O pin	P0_20 TRACE CLK	General purpose I/O pin Trace port clock output
20	Antenna I/O	OUT_ANT	This pin is connected to the internal antenna It should be connected to Pin 22 OUT_MOD for normal operation	OUT_ANT	This pin is connected to the internal antenna It should be connected to Pin 22 OUT_MOD for normal operation
21	Ground	VSS	Must be connected to ground	VSS	Must be connected to ground

Pin & Type		Description for AX version		Description for AL version	
22	Antenna I/O	OUT_MOD	This pin is the RF I/O pin of the BLE module It should be connected to Pin 20 OUT_ANT for normal operation	OUT_MOD	This pin is the RF I/O pin of the BLE module It should be connected to Pin 20 OUT_ANT for normal operation
23	Ground	VSS	Must be connected to ground	VSS	Must be connected to ground
24	Ground	VSS	Must be connected to ground	VSS	Must be connected to ground
25	Ground	VSS	Must be connected to ground	VSS	Must be connected to ground
26	Power	VCC	Power supply (1.7 – 3.6V)	VCC	Power supply (1.7 – 3.6V)
27	Digital I/O	P0_17	General purpose I/O pin	NC	Isolated pad
28	Digital I/O	SWDIO	Serial Wire Debug I/O for debug and programming	SWDIO	Serial Wire Debug I/O for debug and programming
29	Digital I/O	P0_13	General purpose I/O pin	NC	Isolated pad
30	Digital Input	SWDCLK	Serial Wire Debug clock input for debug and programming	SWDCLK	Serial Wire Debug clock input for debug and programming
31	Ground	VSS	Must be connected to ground	VSS	Must be connected to ground
32	Digital I/O	P0_08	General purpose I/O pin	P0_08	General purpose I/O pin
33	Digital I/O	P0_07	General purpose I/O pin	NC	Isolated pad
34	Digital I/O	P0_06	General purpose I/O pin	P0_17	General purpose I/O pin
35	Digital I/O Analog Input	P0_04 AIN2	General purpose I/O pin SAADC/COMP/LPCOMP input	NC	Isolated pad
36	Digital I/O Analog Input	P0_05 AIN3	General purpose I/O pin SAADC/COMP/LPCOMP input	P0_05 AIN3	General purpose I/O pin SAADC/COMP/LPCOMP input
37	Digital I/O	P0_15 TRACE DATA2	General purpose I/O pin Trace port output	NC	Isolated pad
38	Digital I/O Analog Input	P0_03 AIN1	General purpose I/O pin SAADC/COMP/LPCOMP input	P0_03 AIN1	General purpose I/O pin SAADC/COMP/LPCOMP input
39	Digital I/O	P0_27	General purpose I/O pin	NC	Isolated pad
40	Digital I/O Analog Input	P0_02 AIN0	General purpose I/O pin SAADC/COMP/LPCOMP input	P0_01 XL2	Do not connect – Leave floating
41	Digital I/O	P0_25	General purpose I/O pin	NC	Isolated pad
42	Digital I/O Analog Input	P0_31 AIN7	General purpose I/O pin SAADC/COMP/LPCOMP input	P0_00 XL1	Do not connect – Leave floating
43	Digital I/O	P0_11	General purpose I/O pin	NC	Isolated pad
44	Digital I/O Analog Input	P0_30 AIN6	General purpose I/O pin SAADC/COMP/LPCOMP input	P0_15 TRACE DATA2	General purpose I/O pin Trace port output
45	Digital I/O	P0_19	General purpose I/O pin	NC	Isolated pad
46	Digital I/O Analog Input	P0_29 AIN5	General purpose I/O pin SAADC/COMP/LPCOMP input	P0_04 AIN2	General purpose I/O pin SAADC/COMP/LPCOMP input
47	Digital I/O	P0_23	General purpose I/O pin	NC	Isolated pad
48	Digital I/O Analog Input	P0_28 AIN4	General purpose I/O pin	P0_11	General purpose I/O pin
49 to 62	Not Connected	NC	Isolated pad on application PCB for mechanical stability	NC	Isolated pad

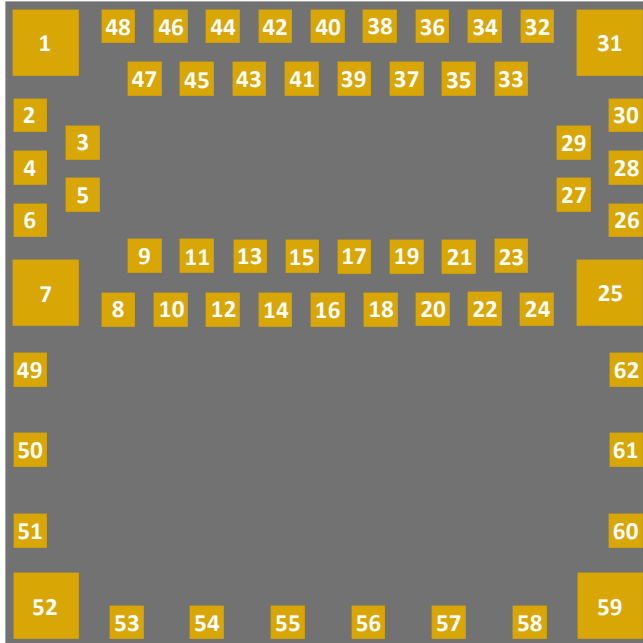

ISP1507
pad placement and pin assignment
for the LGA QFN package

TOP VIEW

4. Mechanical Outlines

4.1. Mechanical Dimensions

Dimensional drawing for 8 x 8 x 1 mm, 62-Pad LGA Package

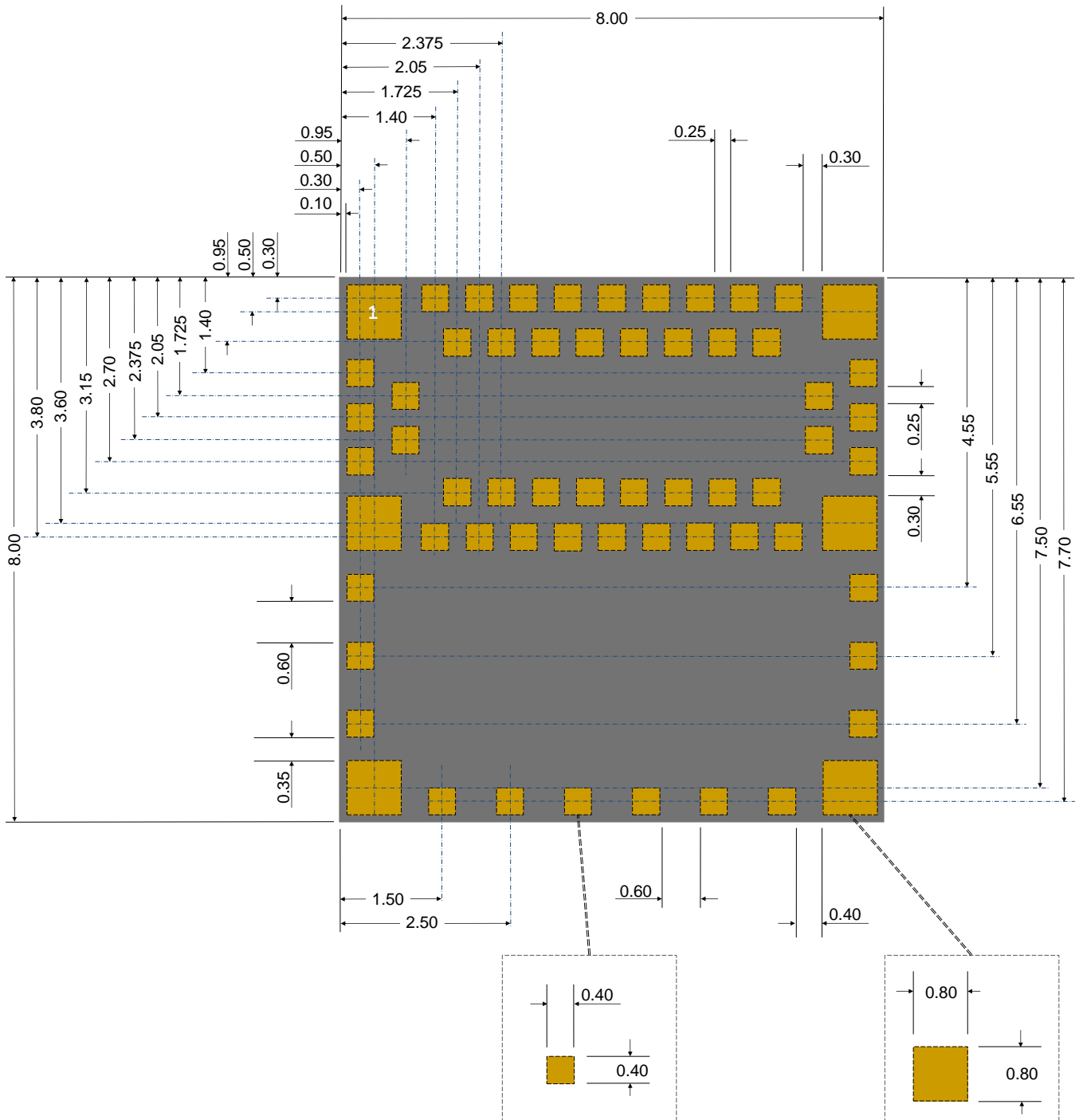

4.2. SMT Assembly Guidelines

For PCB Land Patterns and Solder Mask layout, Insight SiP recommends to use the same dimensions as module pads, ie 0.4 x 0.4 mm for standard pads and 0.8 x 0.8 mm for corner pads.

Please contact Insight SiP for more detailed information.

4.3. Antenna Keep-Out Zone

For optimal antenna performance, it is recommended to respect a metal exclusion zone to the edge of the board: no metal, no traces and no components on any application PCB layer except mechanical LGA pads.

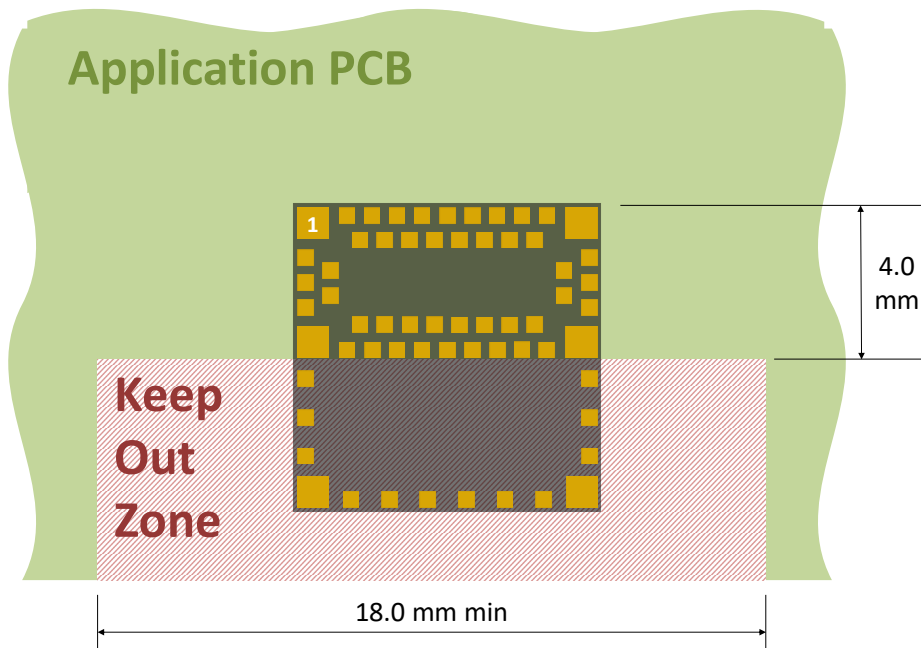

5. Product Development Tools

5.1. Hardware

In order to assist clients in developing their Bluetooth Smart solutions based on the ISP1507, Insight SiP offers an Evaluation Board containing:

- One Interface Board with J-Link Seeger integrated
- One Test Board
- Cables
- NFC Antenna (for the ISP1507-AX version)

Using this evaluation board, product developers can use a working solution as starting point to develop their own products. Time to market is saved by avoiding starting from a blank sheet of paper.

Please refer to the documentation for more information:

http://www.insightsip.com/fichiers_insightsip/pdf/ble/ISP1507/isp_ble_DS1507_DK.pdf

5.2. Firmware

ISP1507 supports Bluetooth Low Energy protocol stacks, ANT protocol stacks as well as 2.4 GHz protocol stacks, including Gazell. For more details regarding SoftDevice stacks and their compatibility with ISP1507 module version, please refer to the Nordic info center at www.infocenter.nordicsemi.com. All stacks can be downloaded at www.nordicsemi.com.

Even though any module version can support any stack, the S112 stack described hereunder is perfectly suited for ISP1507-AL version while S132, S212 and S332 are more dedicated to ISP1507-AX version.

- ✚ The S112 SoftDevice is a Bluetooth low energy peripheral protocol stack solution. It supports up to four peripheral connections with an additional broadcaster role running concurrently. The S112 SoftDevice integrates a Bluetooth low energy Controller and Host and provides a full and flexible API for building Bluetooth low energy ISP1507 solutions.
- ✚ The S132 SoftDevice is a Bluetooth low energy Central and Peripheral protocol stack solution. It supports up to twenty connections with an additional observer and a broadcaster role all running concurrently. The S132 SoftDevice integrates a Bluetooth low energy Controller and Host and provides a full and flexible API for building Bluetooth low energy ISP1507 solutions.
- ✚ The S212 SoftDevice is an ANT protocol stack solution that provides a full and flexible Application Programming Interface (API) for building ANT System on ISP1507 solutions. The S212 SoftDevice simplifies combining the ANT protocol stack and an application on the same CPU.
- ✚ The S332 SoftDevice is a combined ANT™ and Bluetooth low energy (BLE) protocol stack solution. It supports all four Bluetooth low energy roles (Central, Peripheral, Observer, Broadcaster) and ANT.

5.3. Development Tools

The following development tools and software are recommended for using and testing ISP1507 module:

- ✚ Nordic Semiconductor nRFgo Studio:
Downloadable after registering at www.nordicsemi.com.
- ✚ Nordic Semiconductor Master Control Panel:
Downloadable after registering at www.nordicsemi.com.
An alternative remains to use the “nRF Connect” application for Smartphone available on the App Store (iOS device) and on the Play Store (Android device).
- ✚ Debugging and IDE:
SEGGER Embedded Studio (SES):
Downloadable from <https://www.segger.com/products/development-tools/embedded-studio/>

Keil MDK-ARM Lite (limited to 32 KB code)
Downloadable from <https://www.keil.com/demo/eval/arm.htm>.
- ✚ Segger J-Link Lite:
Downloadable from <http://www.segger.com/jlink-software.html>.
- ✚ nRF52 Software Development Kit (SDK):
nRF5-SDK can be downloaded after registering at www.nordicsemi.com. It contains example of source codes applications (C language):
 - Precompiled HEX files
 - Source code
 - SES project files
 - Keil ARM project files
 - IAR project files

6. Reference Designs

6.1. Beacon Design

Beacon board is an autonomous low-power device for wireless detection and transmission. The complete device makes use of Insight SiP ISP1507 BLE module together with low power host processor and small primary button cell battery. It has been developed to explore the full range of development possibilities for beacons using Bluetooth Smart technology. They allow indoor positioning, letting your phone know that you are in range of a beacon. As the “beacon” name suggests, they transmit packets of data in regular intervals, and this data can be then picked up by devices like smartphones.

The two buttons can be programmed to enable easy switching between modes and/or functionality. As well an RGB-LED can be configured to indicate different events.

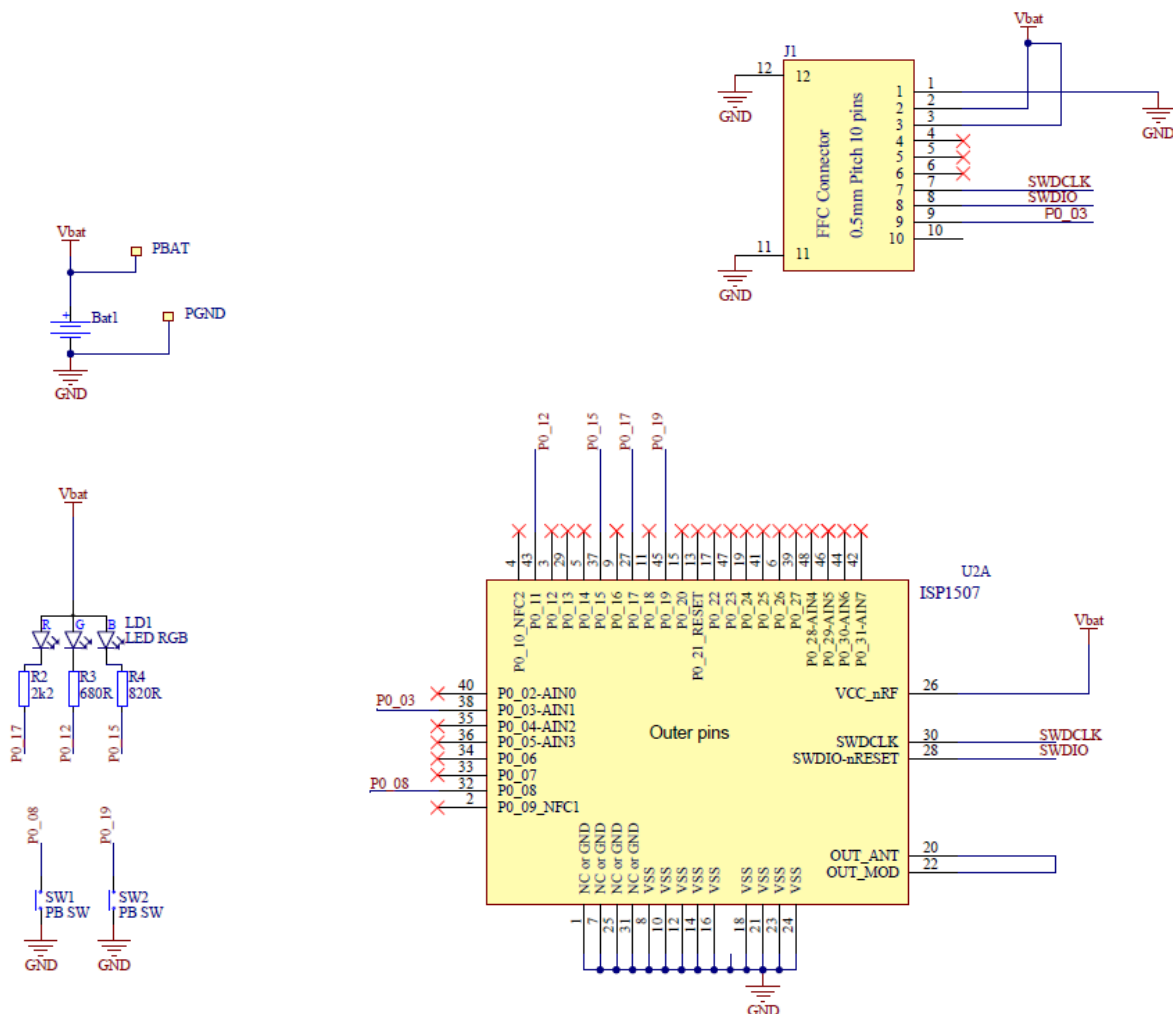

6.2. Sensor Board Design

The ISP1880 is an autonomous low-power device for wireless acceleration, temperature and barometer detection. The complete device makes use of Insight SiP ISP1507 BLE module together with low power Accelerometer/Magneto, Humidity/Temperature and Barometer sensors connected to a primary button cell battery CR2032.

The ST Micro LSM9DS1 is a 3D accelerometer, 3D magnetometer and 3D gyroscope used to detect acceleration and is combined with Sensirion SHTC1 temperature/Humidity and ST Micro LPS22HB barometer sensor. A Rohm SML-P11MTT86 mini-LED is also part of the board and is available to be controlled by software. Data are transmitted via GPIO processor port (I2C, SPI).

ISP1507 Connections

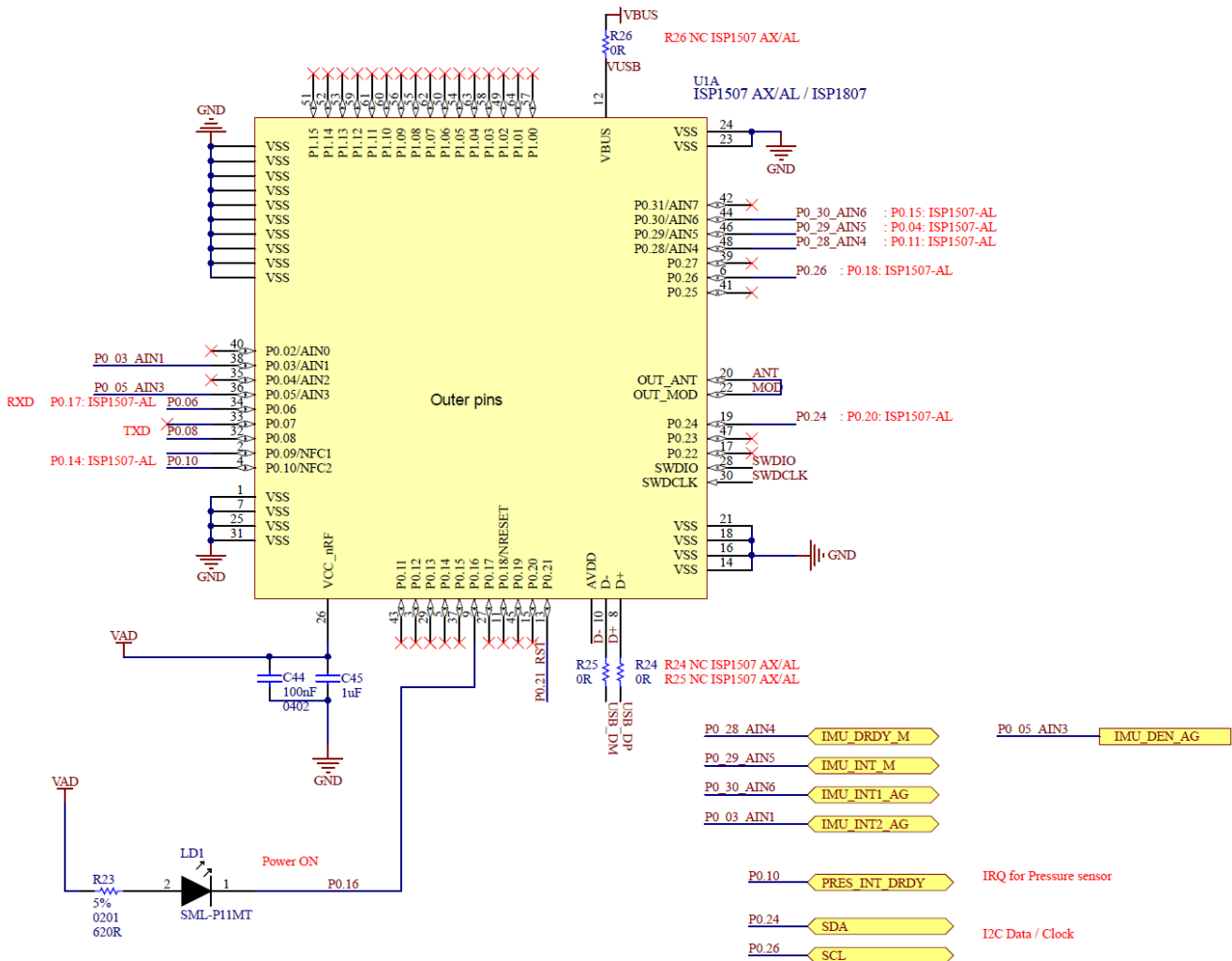

Sensor connections

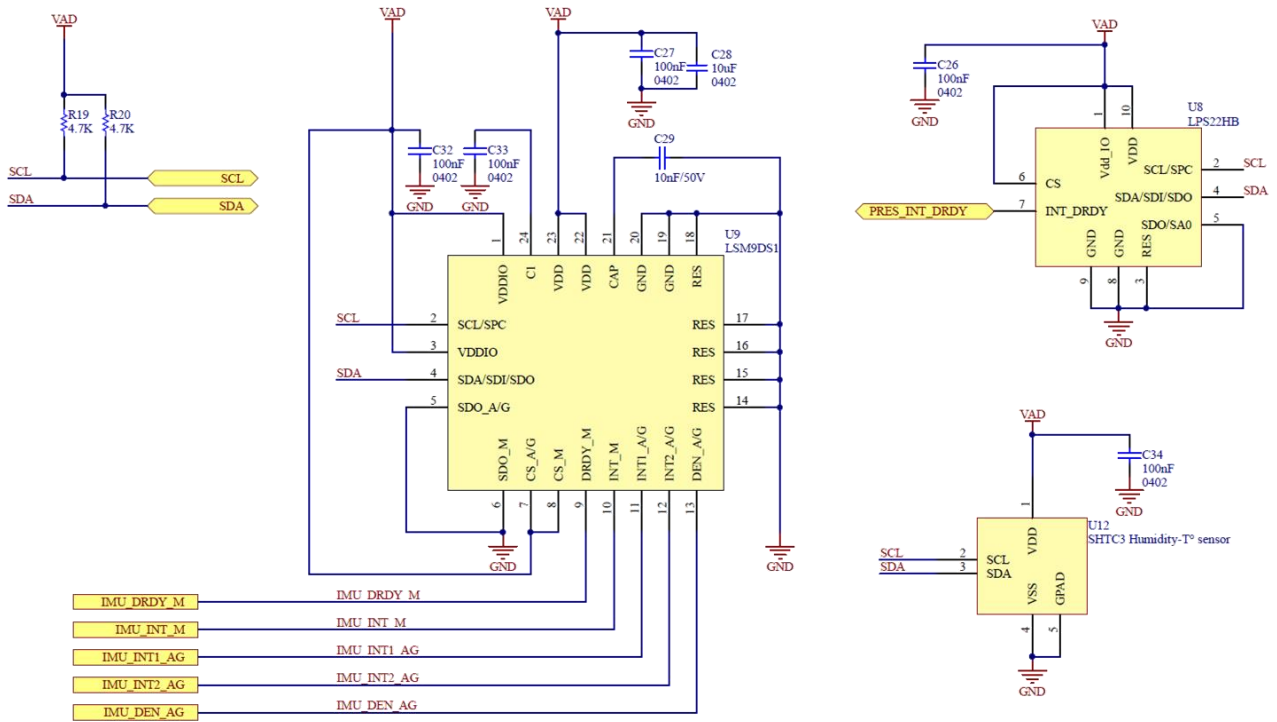

USB Connections

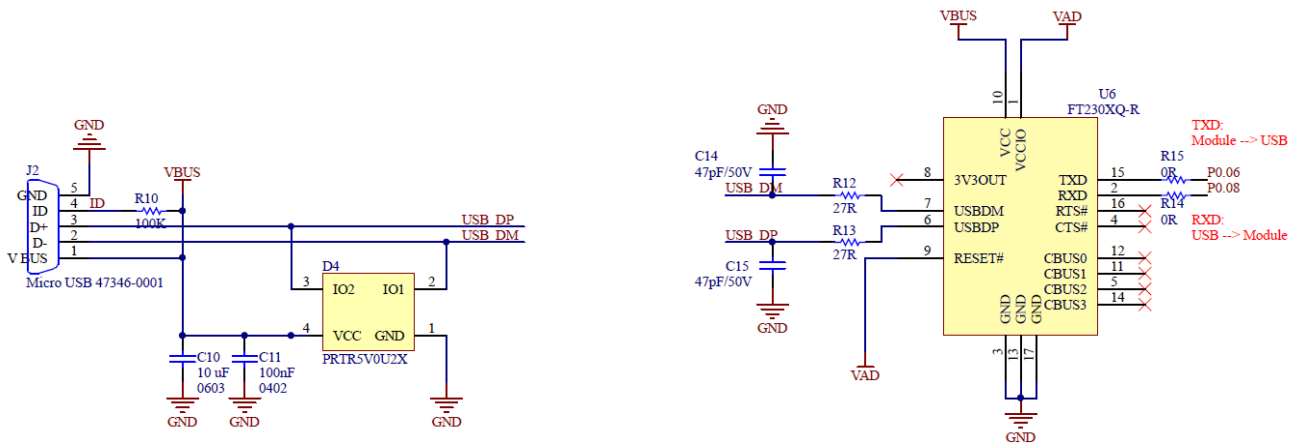

Power Supply

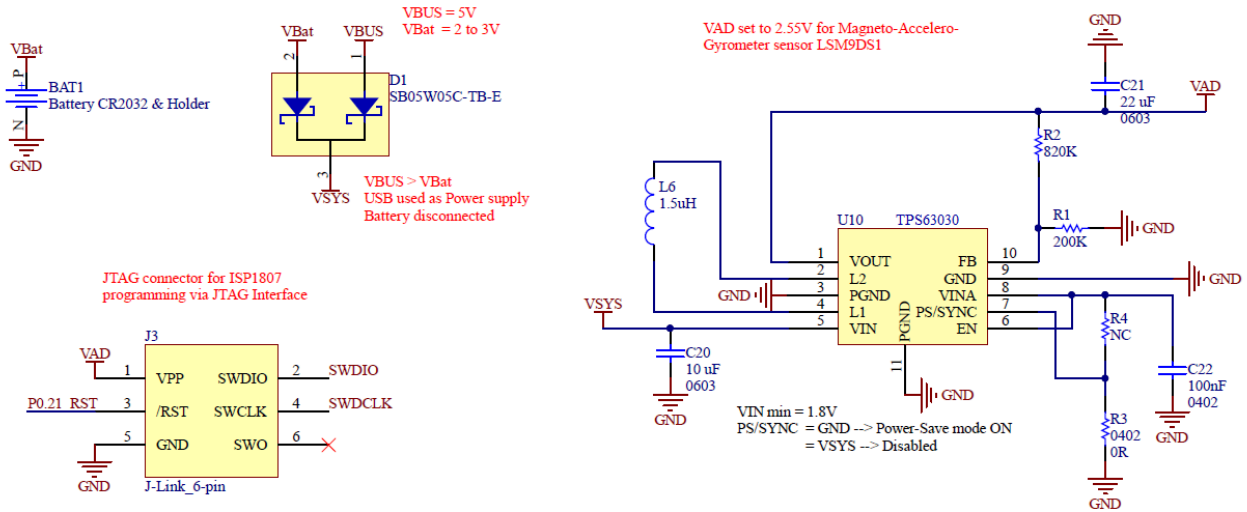

7. Packaging & Ordering information

7.1. Marking

M	/N	:	I	S	P	1	5	0	7
T	T		Y	Y	W	W	R		

ISP1507	Part Number
TT	2 letters Module Type (see section 7.5)
YY	2 digits year number
WW	2 digits week number
R	1 letter Hardware revision

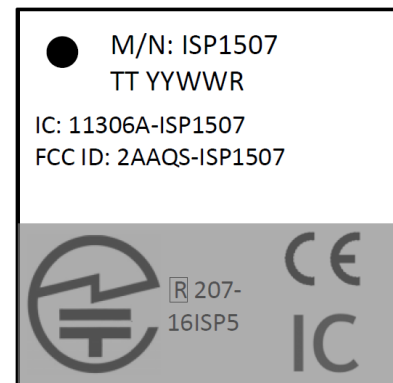

7.2. Prototype Packaging

For engineering samples and prototype quantities up to 99 units, deliveries are provided in thermoformed trays or cut tapes.

They are delivered in sealed pack with desiccant pack and humidity sensors. Please see section 8.2 for more information on moisture sensitivity.

Please order with "ST" code packaging suffix.



7.3. Jedec Trays

For pre-production volumes, ISP1507 are available in Jedec trays. They are delivered in sealed pack with desiccant pack and humidity sensors. These Jedec trays are also suitable for further baking. Please see section 8.2 for more information on moisture sensitivity.

Please order with "JT" code packaging suffix.

Refer to tray sizes below. Complete information on Jedec trays is available on request.

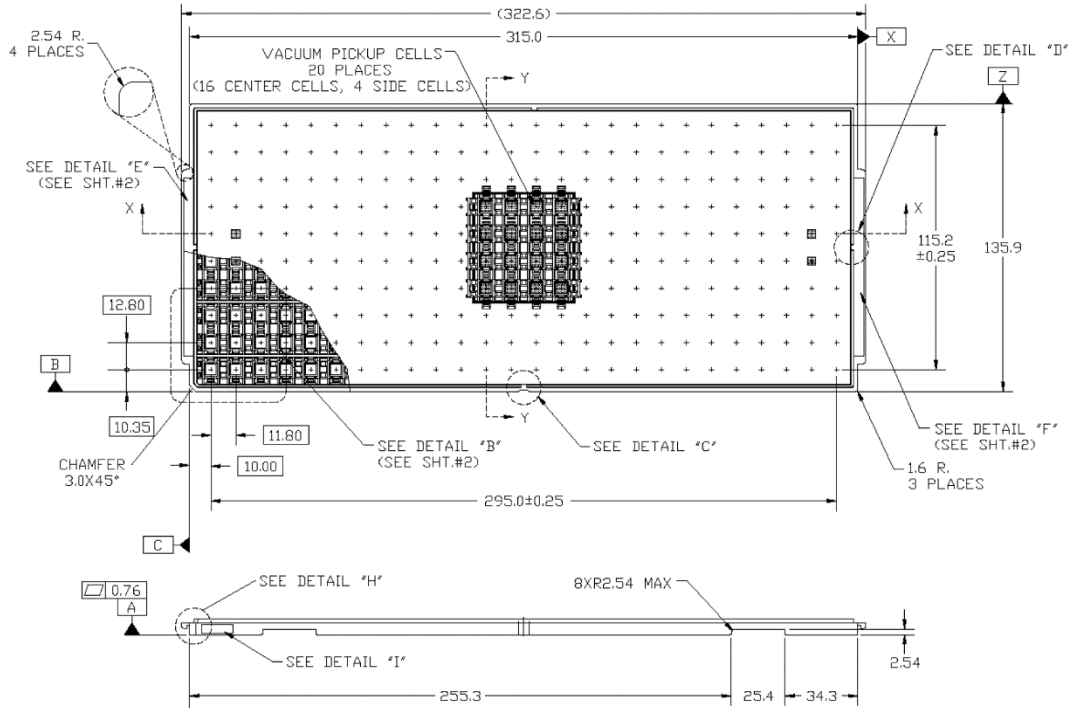

7.4. Tape and Reel

ISP1507 are also available in Tape & Reel. They are delivered in sealed pack with desiccant pack and humidity sensors. Reels are proposed in standard quantities of 500 units (180mm / 7" reel) or 2000 units (330mm / 13" reel) only. Please order with "RS" code packaging suffix for 500-unit reels and "R2" for 2000-unit reels.

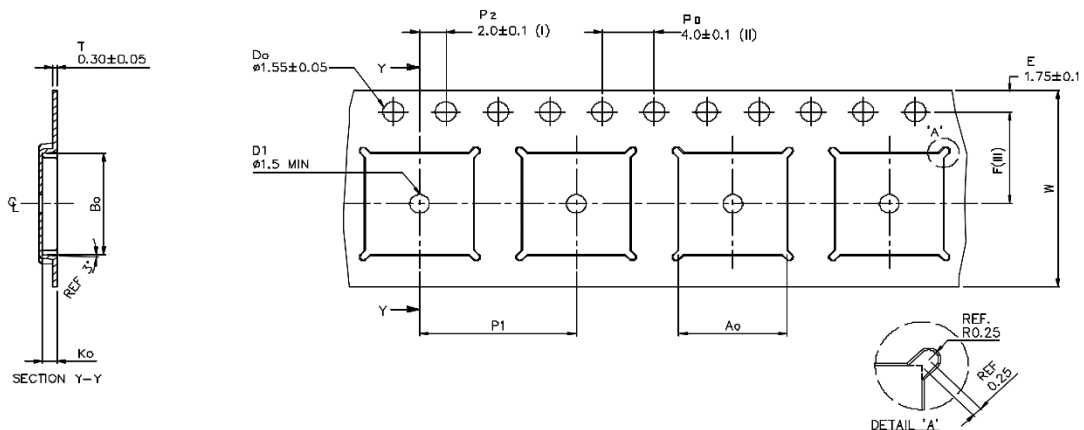

A _o	8.30 +/−0.1
B _o	8.30 +/−0.1
K _o	1.10 +/−0.1
F	7.50 +/−0.1
P ₁	12.00 +/−0.1
W	16.00 +/−0.3

- (I) Measured from centreline of sprocket hole to centreline of pocket.
 (II) Cumulative tolerance of 10 sprocket holes is ± 0.20.
 (III) Measured from centreline of sprocket hole to centreline of pocket.
 (IV) Other material available.

ALL DIMENSIONS IN MILLIMETRES UNLESS OTHERWISE STATED.

7.5. Ordering Information

I	S	P	1	5	0	7	-	T	T	-	Z	Z	
								▼	▼		▼	▼	
								▼	▼		▼	▼	
								▼	▼		▼	▼	
I	S	P	1	5	0	7							Part Number
							-	A					ANT & BLE protocol type
							-		L				192 kB Flash / 24 kB RAM memory type
							-			X			512 kB Flash / 64 kB RAM memory type
													Evaluation Board ⁽¹⁾
							-	E	B				Test board ⁽¹⁾
							-	T	B				Tray or Cut Tape
							-	S	T				Jedec Tray Packaging
							-	J	T				Reel of 500 units
							-	R	S				Reel of 2000 units
							-	R	2				

(1) Please see section 5.1 and refer to the following documentation for more information on evaluation board and test board:

http://www.insightsip.com/fichiers_insightsip/pdf/ble/ISP1507/isp_ble_DS1507_DK.pdf

http://www.insightsip.com/fichiers_insightsip/pdf/ble/ISP1507/isp_ble_AN160601.pdf

8. Storage & Soldering information

8.1. Storage and Handling

- ✚ Keep this product away from other high frequency devices which may interfere with operation such as other transmitters and devices generating high frequencies.
- ✚ Do not expose the module to the following conditions:
 - Corrosive gasses such as Cl₂, H₂S, NH₃, SO₂, or NO_X
 - Extreme humidity or salty air
 - Prolonged exposure to direct Sunlight
 - Temperatures beyond those specified for storage
- ✚ Do not apply mechanical stress
- ✚ Do not drop or shock the module
- ✚ Avoid static electricity, ESD and high voltage as these may damage the module

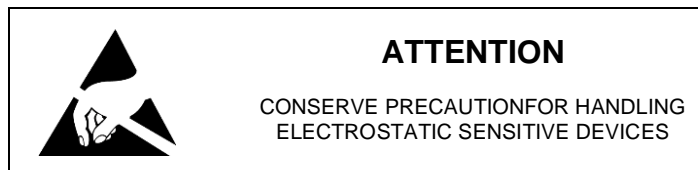

8.2. Moisture Sensitivity

All plastic packages absorb moisture. During typical solder reflow operations when SMDs are mounted onto a PCB, the entire PCB and device population are exposed to a rapid change in ambient temperature. Any absorbed moisture is quickly turned into superheated steam. This sudden change in vapor pressure can cause the package to swell. If the pressure exerted exceeds the flexural strength of the plastic mold compound, then it is possible to crack the package. Even if the package does not crack, interfacial delamination can occur.

Since the device package is sensitive to moisture absorption, it is recommended to bake the product before assembly. The baking process for dry packing is 24 hours at 125°C.

ISP1507 has been tested MSL-3 according to standards. After baking, modules can be exposed to ambient room conditions (approximately 30 °C/60%RH) during 168 hours before assembly on the PCB.



8.3. Soldering information

Recommendation for RoHS reflow process is according to Jedec J-STD-020 and 033 standard profiles.

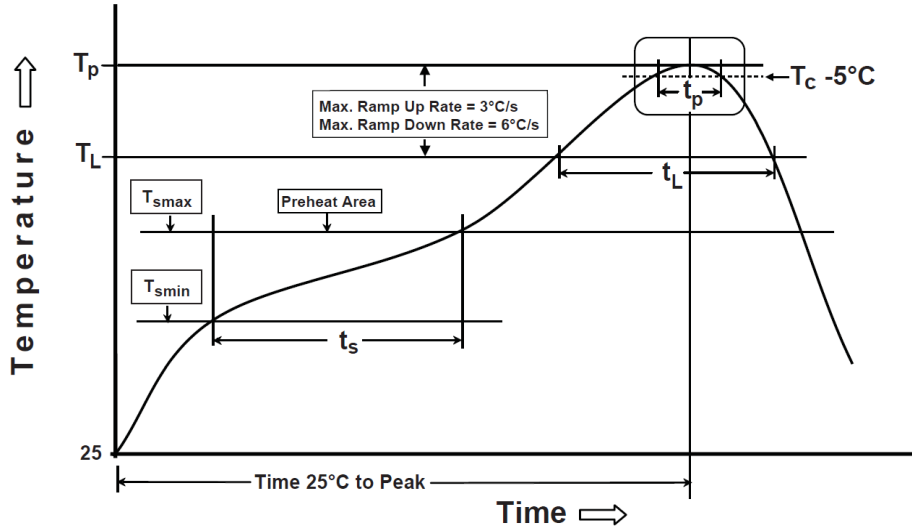

Preheat/Soak	
Temperature Min (T_{smin})	150 °C
Temperature Max (T_{smax})	200 °C
Time (t_s) from (T_{smin} to T_{smax})	60-120 sec
Ramp-up rate (T_L to T_p)	3 °C/sec max
Liquidous temperature (T_L)	217 °C
Time (t_L) maintained above T_L	60-150 sec

Peak package body temperature (T_p)	260°C (+0/-5°C)
Classification Temperature (T_c)	260 °C
Time (t_p) maintained above $T_c - 5$ °C	30 sec
Ramp-down rate (T_p to T_L)	6 °C/sec max
Time 25 °C to peak temperature	8 mn max

9. Quality & User information

9.1. Certifications

- ✚ FCC Identifier 2AAQS-ISP1507
- ✚ CE: Complies with 1999/5/EC, EN300328 V1.9.1 – EC DoC N° TR161102
- ✚ IC– Certification N°11306A-ISP1507
- ✚ TELEC certification N°207-16ISP5
- ✚ Bluetooth SIG certified N° D033110
- ✚ RoHS compliant

9.2. USA – User information

This intends to inform how to specify the FCC ID of our module “ISP1507” on the product. Based on the Public Notice from FCC, the host device should have a label which indicates that it contains our module. The label should use wording such as:

“Contains FCC ID: 2AAQS-ISP1507”

Any similar wording that expresses the same meaning may be used.

The label of the host device should also include the below FCC Statement. When it is not possible, this information should be included in the User Manual of the host device:

*“This device complies with part 15 of the FCC rules. Operation is subject to the following two conditions.
(1) This device may not cause harmful interference
(2) This device must accept any interference received, including interference that may cause undesired operation.
Caution: Any Changes or modifications not expressly approved by the party responsible for compliance could void the user’s authority to operate the equipment.”*

9.3. Canada – User information

This intends to inform how to specify the IC ID of our module “ISP1507” on the product. According to Canadian standards “RSS-210” and “RSS-Gen”, the host device should have a label which indicates that it contains our module. The label should use wording such as:

“Contains IC: 11306A-ISP1507”

Any similar wording that expresses the same meaning may be used.

The label of the host device should also include the below IC Statement. When it is not possible, this information should be included in the User Manual of the host device:

“This device complies with Industry Canada licence-exempt RSS standard(s). Operation is subject to the following two conditions: (1) this device may not cause interference, and (2) this device must accept any interference, including interference that may cause undesired operation of the device.

Le présent appareil est conforme aux CNR d'Industrie Canada applicables aux appareils radio exempts de licence. L'exploitation est autorisée aux deux conditions suivantes : (1) l'appareil ne doit pas produire de brouillage, et (2) l'utilisateur de l'appareil doit accepter tout brouillage radioélectrique subi, même si le brouillage est susceptible d'en compromettre le fonctionnement.”

9.4. RF Exposure Information

This equipment complies with FCC/IC radiation exposure limits set forth for an uncontrolled environment and meets the FCC radio frequency (RF) Exposure Guidelines in Supplement C to OET65 and RSS-102 of the IC radio frequency (RF) Exposure rules. This equipment has very low levels of RF energy that it deemed to comply without maximum permissive exposure evaluation (MPE).

9.5. Informations concernant l'exposition aux fréquences radio (RF)

La puissance de sortie émise par l'appareil de sans-fil est inférieure à la limite d'exposition aux fréquences radio d'Industry Canada (IC). Ce module a également été évalué et démontré conforme aux limites d'exposition aux RF d'IC dans des conditions d'exposition à des appareils mobiles et/ou portables.

9.6. Discontinuity

Normally a product will continue to be manufactured as long as all of the following are true:

- The manufacturing method is still available.
- There are no replacement products.
- There is demand for it in the market.

In case of obsolescence, Insight SiP will follow Jedec Standard JSD-48. A Product Discontinuation Notice (PDN) will be sent to all distributors and made available on our website. After this, the procedure goes as follows:

- Last Order Date will be 6 months after the PDN was published.
- Last Shipment Date will be 6 months after Last Order Date, i.e. 12 months after PDN.

9.7. Disclaimer

Insight SiP's products are designed and manufactured for general consumer applications, so testing and use of the product shall be conducted at customer's own risk and responsibility. Please conduct validation and verification and sufficient reliability evaluation of the products in actual condition of mounting and operating environment before commercial shipment of the equipment. Please also pay attention (i) to apply soldering method that don't deteriorate reliability, (ii) to minimize any mechanical vibration, shock, exposure to any static electricity, (iii) not to overstress the product during and after the soldering process.

The products are not designed for use in any application which requires especially high reliability where malfunction of these products can reasonably be expected to result in personal injury or damage to the third party's life, body or property, including and not limited to (i) aircraft equipment, (ii) aerospace equipment, (iii) undersea equipment, (iv) power plant control equipment, (v) medical equipment, (vi) transportation equipment, (vii) traffic signal equipment, (viii) disaster prevention / crime prevention equipment.

The only warranty that Insight SiP provides regarding the products is its conformance to specifications provided in datasheets. Insight SiP hereby disclaims all other warranties regarding the products, express or implied, including without limitation any warranty of fitness for a particular purpose, that they are defect-free, or against infringement of intellectual property rights. Insight SiP customers agree to indemnify and defend Insight SiP against all claims, damages, costs and expenses that may be incurred, including without any limitation, attorney fees and costs, due to the use of products.



Insightsip.com 代理商联系方式:

样品, 技术支持, 参考设计, 评估板, 报价购买请联系

电话:0755-82565851

邮件:dwin100@dwintech.com

手机:156-2521-4151

网址: <http://www.dwintech.com/insight%20Pamphlet.html>

深圳市南频科技有限公司

D-Win Technology (HongKong) Co., Ltd